

Compact Gas Sample Probe Series SP[®]

SP180-H-EX2 T2

SP180-H-EX2 T3

SP180-H-EX2 T4

⊕ Ex II 3G Ex ec mc IIC T2/T3/T4 Gc

Instruction Manual
Version 1.00.02



**Dear customer,**

Thank you for buying our product. In this instruction manual you will find all necessary information about this M&C product. The information in the instruction manual is fast and easy to find, so you can start using your M&C product right after you have read the manual.

If you have any question regarding the product or the application, please don't hesitate to contact M&C or your M&C authorized distributor. You will find all the addresses in the appendix of this manual.

For additional information about our products and our company, please go to M&C's website www.mc-techgroup.com. There you will find the data sheets and manuals of all our products in German and English.

Disclaimer

This manual does not claim to be complete and it may be subject to technical modifications.

© 03/2021 M&C TechGroup Germany GmbH. Reproduction of this document or its content is not allowed without permission from M&C.

Version: 1.00.02

Table of Contents

1	General information	4
2	Declaration of conformity	4
3	Safety instructions	5
4	Warning signs and definitions	6
5	Information regarding the usage in explosive atmospheres	8
6	Warranty	9
7	Introduction	10
7.1	Serial numbers	10
7.2	Power supply	10
8	Technical Data	11
9	Applications	12
10	Description	13
11	Probe design	14
12	Receiving the sample probe	15
13	Preparation for Installation	15
14	Installation	16
14.1	Connecting the heated sample line	18
14.2	Connecting the test gas line	18
15	Electrical Connection	19
16	Starting up	20
17	Maintenance	21
18	Decommissioning	24
19	Spare parts and consumables	25
20	Appendix	25

Table of Figures

Figure 1	Dimensions and construction of the SP180-H-EX2 T*	14
Figure 2	Mounting of the SP180-H-EX2 T*	17
Figure 3	Electrical connection diagram	19
Figure 4	Opening of the insulation cap.....	22
Figure 5	Replacing the filter element.....	23

Headquarters

M&C TechGroup Germany GmbH ♦ Rehhecke 79 ♦ 40885 Ratingen ♦ Germany

Phone: +49 - 2102 - 935 – 0

Fax: +49 - 2102 - 935 - 111

E - mail: info@mc-techgroup.com

Website: www.mc-techgroup.com

1 General information

The product described in this manual has been built and tested in our production facility.

All M&C products are packed to be shipped safely. To ensure the safe operation and to maintain the safe condition, all instructions and regulations stated in this manual need to be followed. This manual includes all information regarding proper transportation, storage, installation, operation and maintenance of this product by qualified personnel.

Follow all instructions and warnings closely.

Read this manual carefully before commissioning and operating the device. If you have any questions regarding the product or the application, please don't hesitate to contact M&C or your M&C authorized distributor.

2 Declaration of conformity



The product described in this operating manual complies with the following EU directives:

ATEX-Directive

The product described in this manual is produced in accordance with the EU directive for devices and protection systems for appropriate use in hazardous areas 2014/34/EU appendix II.

EMV-Instruction

The requirements of the EU directive 2014/30/EU “Electromagnetic compatibility“ are met.

Low Voltage Directive

The requirement of the EU directive 2014/35/EU “Low Voltage Directive“ are met.
The compliance with this EU directive has been examined according to DIN EN 61010.

Declaration of conformity

The EU Declaration of conformity can be downloaded from the **M&C** homepage or directly requested from **M&C**.

3 Safety instructions

Follow these safety directions and instructions regarding installation, commissioning and operation of the SP180-H-EX2 T*:

Read this manual before commissioning and operating the product. Make sure to follow all safety instructions.

Installation and commissioning of electrical devices must be carried out only by qualified skilled personnel in compliance with the current regulations.

The installation and commissioning of the device must conform to the requirements of VDE 0100 (IEC 364) 'Regulations on the Installation of Power Circuits with Nominal Voltages below 1000 V' and must be in compliance with all relevant regulations and standards.

Attention should be paid to all relevant national and international regulations and standards regarding the usage of the device in potentially explosive atmospheres.

Before connecting the device, please make sure to compare the supply voltage with the specified voltage on the product label.

Protection against damages caused by high voltages:

Disconnect the power supply before opening the device for access. Make sure that all external power supplies are disconnected.

Operate the device only in the permitted temperature and pressure ranges. For details please refer to the technical data sheet or manual.

Install the device only in protected areas, sheltered from rain and moisture. The product should not be exposed to the elements.

Installation, maintenance, inspections and any repairs of the devices must be carried out only by qualified skilled personnel in compliance with the current regulations.

4 Warning signs and definitions



Danger

The 'Danger' warning sign indicates that death, serious injury and/or significant material damage will be the consequence, if the appropriate precautions should not be taken.



Warning

The 'Warning' warning sign indicates that death, serious injury or damage to property may occur if the relevant precautionary measures are not observed.



Caution

The 'Caution' warning sign indicates that slight personal injury can occur if the appropriate safety precautions are not observed.

Caution

'Caution' indicates that damage to property can occur if the appropriate safety precautions are not observed.

Attention

'Attention' indicates that an unintended result or situation can occur if the corresponding information is not taken into account.



Note

'Note' indicates important information relating to the product or highlights parts of the documentation for special attention.

Qualified personnel

'Qualified personnel' are experts who are familiar with the installation, commissioning, maintenance and operation of these types of products. The following knowledge is at least required for the work:

- Instructed person in EX-protection
- Trained person in the electrotechnical field
- Detailed knowledge of the manual and the applicable safety regulations



'Ex' indicates important information about the product or about the corresponding parts in the instruction manual, relating to usage in potentially explosive atmospheres.



High voltages!
Protect yourself and others against damages which might be caused by high voltages.



Hot surface!
Contact may cause burn! Do not touch!



Wear protective gloves!

Working with chemicals, sharpe objects or extremely high temperatures requires wearing protective gloves.



Wear safety glasses!

Protect your eyes while working with chemicals or sharpe objects. Wear safety glasses to avoid getting something in your eyes.



Wear protective clothes!

Working with chemicals, sharpe objects or extremely high temperatures requires wearing protective clothes.

5 Information regarding the usage in explosive atmospheres

The device can be operated in potentially explosive atmosphere of explosive zone 2 (see Ex certification in the appendix)

The Ex marking for the SP180-H-EX2 T* is:

 II 3G Ex ec mc IIC T2/T3/T4 Gc

The sample gas probe is certified by DEKRA EXAM GmbH.

You will find a copy of the Type Examination Certificate in the appendix of this instruction manual. Follow closely all specified conditions and installation instructions stated in the Type Examination Certificate (see appendix) regarding the installation and operation of the sample probe.



Only by complying to all requirements stated in the Type Examination Certificate, safe operation in explosive atmospheres is ensured.

Any modification of the standard configuration of the sample probe with parts, which are not approved by M&C and not explicitly specified for usage in explosive atmospheres, will void the Type Examination Certificate. This also refers to any repair work and service using parts which are not M&C approved and not specified for usage in explosive atmospheres.

Please don't hesitate to contact M&C or your M&C distributor if you have any questions about parts, repair work and services of the SP180-H-EX2 T*.

Protect yourself and others against damages which might be caused by high voltage. Disconnect power supply before opening the device for access. Make sure that all external power supplies are disconnected.



Warning

Always clean protection cover with damp cleaning wipes.

Prevent electrostatic discharge during installation and operation! Avoid buildup of electrostatic electricity caused by operation, maintenance or cleaning of the device.



6 Warranty

In case of a device failure, please contact immediately M&C or your M&C authorized distributor.

We have a warranty period of 12 months from the delivery date. The warranty covers only appropriately used products and does not cover the consumable parts. Please find the complete warranty conditions in our terms and conditions.

The warranty includes a free-of-charge repair in our production facility or the free replacement of the device. If you return a device to M&C, please be sure that it is properly packaged and shipped with protective packaging. The repaired or replaced device will be shipped free of delivery charges to the point of use.

7 Introduction

M&C gas sample probes provide direct insitu ultra-fine filtration during continuous gas sampling for analytic measurements. In this way, part of the necessary maintenance work for a system is concentrated on a single point. This filter technology has the major advantage that dust mixtures consisting of ultra-fine and coarse dusts can be optimally retained with the least possible maintenance work.

Optimal adaptation of the sample probe to processing conditions and to measurement work is a necessary condition for a measurement system to work smoothly. Basically, the gas sample should be kept to a necessary minimum. This is made possible thanks to optimised downstream gas processing using M&C components. Only in this way it is possible to reduce maintenance to a minimum while ensuring maximum availability.

The SP180-H-EX2 T* is certified for appropriate use in the specified Ex zones.



Only operate the gas sample probe according to the specifications stated in this instruction manual and in the extended manufacturer documents.

The gas sample probe is classified for three different temperature classes:

Version	Operating temperatur [°C] from -20 to 80 °C [-4 °F to +176 °F] ambient temperatur	Max. Surface temperatur [°C]
SP180-H-EX2 T2	180 [356 °F]	240 [464 °F]
SP180-H-EX2 T3	155 [311 °F]	180 [356 °F]
SP180-H-EX2 T4	100 [212 °F]	130 [266 °F]



Table 1 SP180-H-EX2 T* temperature classification

A one alarm contact (low temperature alarm) is available to monitor the temperature of the gas sample probe:

- Switching temperature: version **SP180-H-EX T2 / T3** < 90 °C [194 °F]
- Switching temperature: version **SP180-H-EX T4** < 90 °C [194 °F]

7.1 Serial numbers

The product label with the serial number is located inside the terminal box of the sample probe.

Please refer to this serial number if you have any questions about your sample probe or if you need to order spare parts or consumables.

7.2 Power supply

The probe can be operated on alternating current in the range of 110 VAC to 240 VAC, 50 to 60 Hz.

8 Technical Data

Gas Sample Probe Series SP®	SP180-H-EX2 T2	SP180-H-EX2 T3	SP180-H-EX2 T4
Part No.	02S1890	02S1885	02S1880
Protective cover	Yes		
Outdoor mounting	Yes		
Sample temperature	Max. 600 °C* [1112 °F*]		
Sample pressure	0.4 to 6 bar abs.		
Ambient temperature	-20 °C to +80 °C [-4 °F to +176 °F]		
Dust load	Up to 1 g/m ³ *		
Filter chamber volume	70 ml		
Filter element	S-2K, filter porosity 2 µm, ceramic (others on request)		
Probe heating	150 – 180 °C [302 to +356 °F] self-regulating	120 – 160 °C [248 to +320 °F] self-regulating	90 – 120 °C [194 to +248 °F] self-regulating
Ready for operation	After 2 hours		
Low temperature alarm contact, alarm point	< 90 °C [194 °F], NO	< 90 °C [194 °F], NO	< 90 °C [194 °F], NO
Low temperature alarm contact, contact rating	250 V-1.5 A AC, 0.5 A DC		
Connection sample gas outlet	1/4"-NPT inside, with Ø 6 mm (DN4/6) Swagelok® tube connector		
Connection calibration gas	Ø 6 mm (DN4/6) Swagelok® tube connector		
Power supply	110 VAC up to 240 V 50 to 60 Hz, rated current 3.5 A		
Power consumption	Typically: 100 VA, (fuse 6 A)		
Electrical connection	Terminals max. 2.5 mm ² , cable fittings: 1 x M20 and 1 x M16		
Mounting flange	DN65 PN6, B stainless steel 316Ti		
Material of sample contacting parts	SS 316 / 316Ti, FKM, ceramic		
Degree of protection/ Electrical equipment standard	IP54, EN 60529/EN 61010,		
Ex Certification	⊕ II 3G Ex ec mc IIC T2 Gc	⊕ II 3G Ex ec mc IIC T3 Gc	⊕ II 3G Ex ec mc IIC T4 Gc
	EXAM BVS 16 ATEX E 039		
Ex Standards	EN 60079-0:2012 + A11:2013, EN 60079-7:2015, EN 60079-18:2009		
Dimensions (W x H x D)	230 x 280 x 225 mm [≈ 9.1" x 11.0" x 8.9"]		
Weight	Approx. 7.5 kg [≈ 16.5 lbs]		
Flow	Max. 500 NI/h		

Option	
Part No. 02S9200	Insitu probe tube out of stainless steel 316Ti type SP210/SS, connection G 3/4" o, ø 10/12, length 1 m [≈ 3.28 ft.]*, incl. flange gasket.

* Standard, other versions on request.

ΔP und T_{90} at flow of:	100	200	500	NI/h
ΔP pressure loss with new filter element S-2K:	4	7	15	mbar
T_{90} time-with sample tube SP210/SS-	4.0	2.5	< 1.0	Sec.

Swagelok® is a registered trademark for tube fittings by Swagelok Company, USA.

Please note: NI/h and NI/min refer to the German standard DIN 1343 and are based on these standard conditions: 0 °C [32 °F], 1013 mbar.

9 Applications

The electrically heated M&C gas sample probe SP180-H-EX2 T* is used for continuous gas sampling in processes with dust densities of up to 1 g/m³, operating pressure of up to max. 6 bar abs., temperatures of up to a maximum of 600 °C [1112 °F] or for high gas humidity. Thanks to its compact design it requires only limited space. The gas sample probe SP180-H-EX2 T* is equipped with a new protective cover and can be used for outdoor mounting.

Do not use the sample gas probe to extract gases or gas compositions, which could be potentially explosive without the presence of air. Do not use gases or gas compositions which can alter the relevant safety-related material properties of the probe materials. The gas or gas composition needs to be free of particles which could cause, in combination with the materials of the gas sample probe, sparks by friction or impact.

This also applies to specific gases or gas compositions, which enter the gas sample probe via the calibration gas adapter connection. Make sure that all gases or gas compositions which enter the sample gas probe, do not react with the environment or the process.

Prevent any potential source of ignition (for example burning or smoldering particles, small smoldering fires, foreign objects) from entering the gas sample probe during operation.



10 Description

The sample probe is designed for easy installation, reliable operation and trouble-free maintenance. Advantages are:

- Gas sampling with dust-laden processes;
- low volume, fast response time;
- filter elements can be changed without tools and without disconnecting the (heated) sample line;
- the filter chamber can be easily cleaned;
- the probe tube can be cleaned without dismantling the probe;
- self-regulated electrical heating with undertemperature alarm contact, and different probe tubes and pre-filters as option;
- with calibration gas connection as standard.

The 75 mm [\approx 2.95"] ceramic filter element with a porosity of 2 μ m and a large surface is located in the heated stainless steel filter housing of the probe. The gas sample probe can be heated to a maximum temperature of 120 °C [248 °F]/155 °C [311 °F]/180 °C [356 °F] (see temperature-classifications in the technical data table). using a special self-regulated heating element. No thermostat or temperature limiter is necessary. A separate thermo switch is provided for under temperature monitoring (NO).

11 Probe design

The probe head with its new all-round enclosing heat insulating protection cover forms a complete unit with the filter housing, the standard mounting flange DN65 PN6 and the junction box which is attached to the side.

A mounting clamp and a tube connector are located at the bottom of the probe for the connection of heated M&C sampling lines with outer diameters of 40 mm [≈ 1.57 "] to a max. of 55 mm [≈ 2.17 "].

Please feel free to contact us in order to select an appropriate heated M&C sample line for your application.

The sample gas outlet at the probe is designed for a 6 mm (DN4/6) tube.

The stainless steel sampling tube of one meter length (Part No.: 02S9200) can optional be provided and is connected to the G 3/4" thread of the mounting flange. The maximum operating temperature for the stainless steel sampling tube is 600 °C [1112 °F]. The modular system of our sample probes allows the usage of all M&C sample tubes and prefilters with G 3/4" connection thread. This guarantees an optimum adaptation to the process conditions.

The following cross-sectional drawing shows the probe SP180-H-EX2 T*.

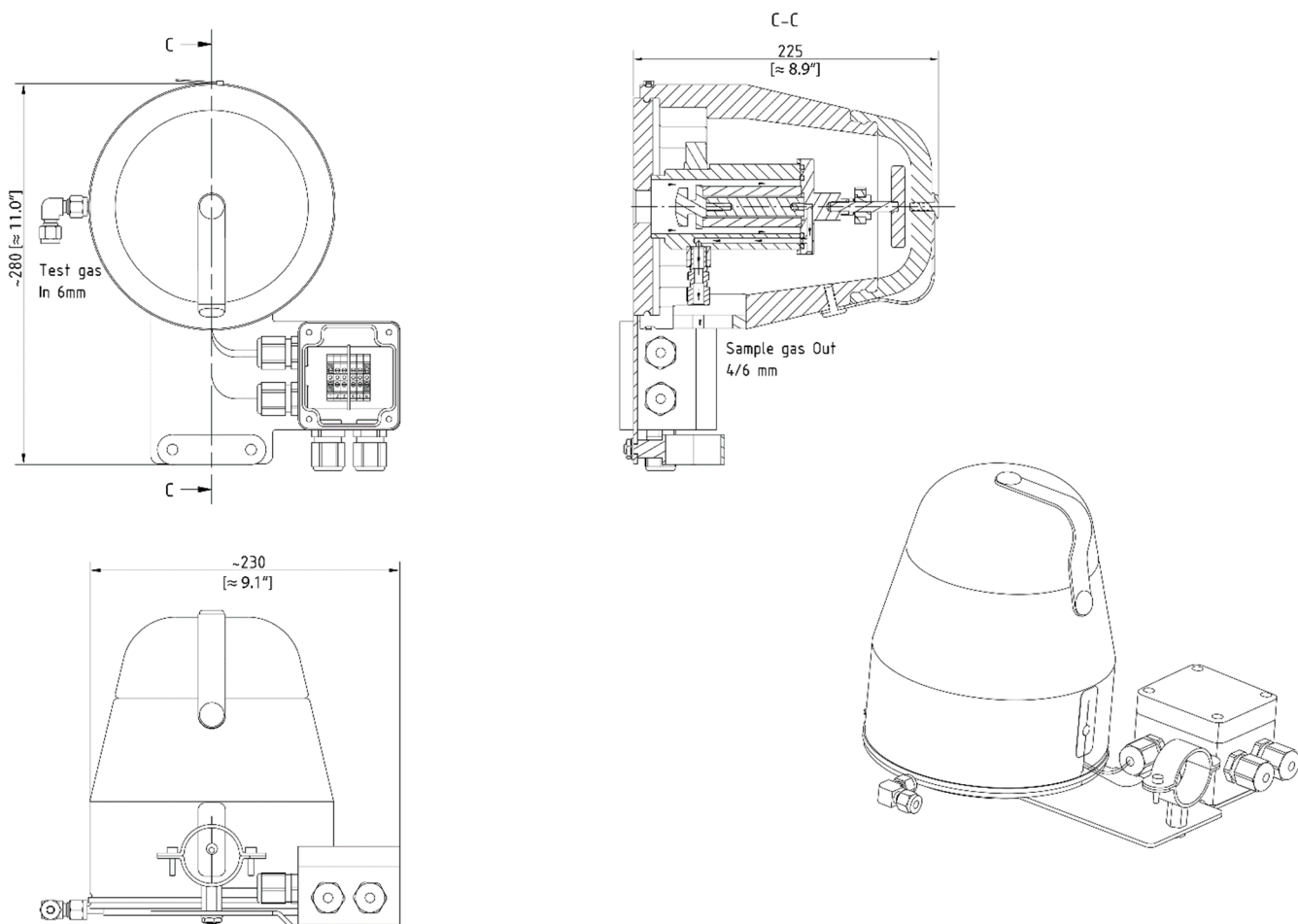

Figure 1 Dimensions and construction of the SP180-H-EX2 T*

12 Receiving the sample probe

The gas sample probe is usually delivered in two packaging units:

- The gas sample probe with the required screws, nuts and flange sealing.
- Sample tube with gasket.

Please remove the gas sample probe carefully from the packaging. Check the scope of the delivery specified on the delivery note. Please make sure that you have received all items stated on the delivery note. Please check the unit for any transport damages after receipt and report any complaints to the transport company immediately.

13 Preparation for Installation



Warning



Make sure that the temperature classification of the gas sample probe corresponds to the ignition temperature of the combustion gases/vapors.

- Select the optimum sampling point in accordance to the generally applicable guidelines or by consulting the relevant person or department.
- Choose the sampling point location, while keeping in mind that this location has adequate space for inserting and removing of the probe. Please consider the insertion length of the probe tube when you choose the location of the sampling point.
- The probe needs to be easily accessible for all necessary maintenance work.
- The temperature of the sample probe connections needs to be always above the acid dew point in order to avoid corrosion and problems with blockage. If this is not possible, a heated SP35/SP30 probe tube is recommended for cold connections.
- If the ambient temperature in the area of the connections is $>80\text{ }^{\circ}\text{C}$ [$>176\text{ }^{\circ}\text{F}$] as a result of radiant heat, a reflector needs to be installed to protect the probe.
- The mounting flange connector of the sample probe should be in compliance with DN65 PN6. If other connection sizes are required, a special adapter flange /S010 can be ordered optional.
- The probe needs to be fitted to the existing operating conditions before mounting.

The following existing operational parameters need to be checked prior to installing the sample probe:

weatherproof mounting position	_____provided	_____needs to be installed	
Under / over pressure situation	mbar	bar	
Process temperature	°C, Min.	°C, Max.	
Dust loading	g/m ³		
Dust composition - grain size	µm		
Gas composition	corrosive	toxic	explosive
Which parameters should be measured, e.g. O₂, CO, SO₂, NO_x,...	vol%	mg/Nm ³	ppm
Required amount of gas	l/h, Min.	l/h, Max.	
Necessary T₉₀ time	sec.		

Operating parameters of combustion gas			
Gas composition	<input type="checkbox"/> <input type="checkbox"/> corrosive	<input type="checkbox"/> <input type="checkbox"/> toxic	<input type="checkbox"/> <input type="checkbox"/> explosive
Zone classification of process conditions			
Zone classification of ambient conditions			
Ignition temperature of gases or vapours	°C (>max. surface temperature from table 1)	Corresponds to temperature classification	
Explosion group	<input type="checkbox"/> <input type="checkbox"/> IIA	<input type="checkbox"/> <input type="checkbox"/> IIB	<input type="checkbox"/> <input type="checkbox"/> IIC

14 Installation



Warning

Do not install sample gas probe while potentially explosive atmosphere is present.



The process and the environment of the probe needs to be explosion-free (explosion-free zone) during installation. A zone is declared as explosion-free zone, if it is free of explosive atmosphere.



Warning

Connect the probe to earth (electrical bonding terminal). The bleeder resistor needs to have an overall value of < 10⁶ Ω. The protection cover does not need to be connected to earth. Following the maintenance procedure, the protection cover needs to be cleaned by damp cleaning wipes.

The M&C SP180-H-EX2 T* probe is designed for stationary use. The professional choice of the right sample probe for the application and the professional installation guarantees a long service life and minimum maintenance work. The ideal position for mounting the sample probe is horizontally with a tilt angle of 10 % towards the process. Please follow these installation steps and see details in Figure 2.

- Screw the sample probe tube directly into the $\frac{3}{4}$ " inner thread ⑥ of the probe flange and tighten it.
- To mount the SP180-H-EX2 T* at the sampling flange, please loosen the metal clamp ⑦ around the heat insulating protection cover and remove the cover ⑧.
- If the probe connection is not the same size as the standard flange connection DN65 PN6, an adapter flange ② (optional) should be mounted to the probe (see Figure 2). Place the gasket ③ between the adapter flange and the probe flange.
- If the heated probe tube type SP30/35 is used then the probe is to be screwed to its flange (with welded threaded bolt). First insert the flange seal ③ between the two flanges.
- Attach the flange seal ③ to the probe connection.
- Insert sample probe with mounted probe tube into the connection piece and fasten the probe using the supplied bolts and nuts.
- After mounting of the probe at the sampling flange put the heat insulating protection cover ⑧ over the probe flange again and secure it with the metal clamp ⑦.



Note

For the preferred mounting position of the probe, the sample gas outlet is pointing downwards. This is just the preferred mounting position, it is not necessary for correct operation.

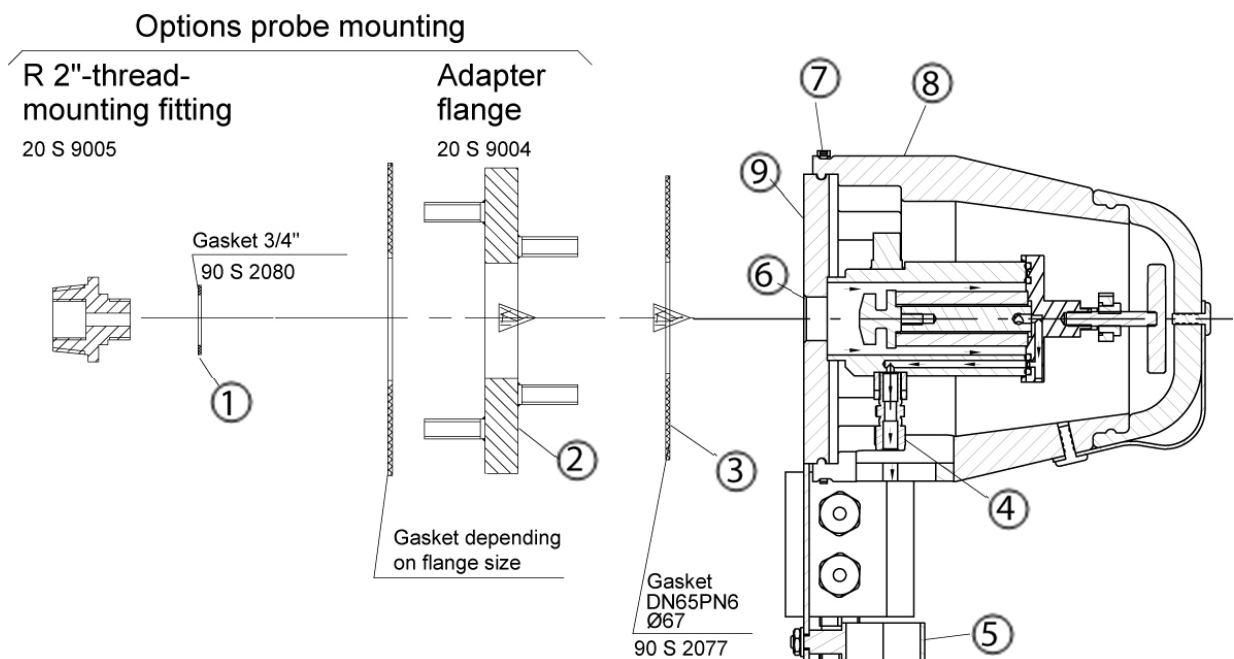

Figure 2 **Mounting of the SP180-H-EX2 T***

14.1 Connecting the heated sample line

- To connect the sample line, a threaded tube connector ④ with $\text{Ø } 6 \times 1 \text{ mm}$ is available – other diameters available on request.
- Open metal clamp ⑤.
- Insert the tube connection piece into the bolted pipe joint ④ and connect them.
- If you use a PTFE tube as sample line, a metal tubing sleeve for pneumatic fittings needs to be inserted at the end of the tube to prevent it of being pressed together.
- The temperature-resistant, stainless steel connector ④ from M&C has a double-blade ring system to ensure reliable sealing. First finger-tight the nut of this connector, then use a flat spanner to turn the nut exactly $1\frac{1}{4}$ -turns. The nut is now correctly mounted.
- Place the heated sample line into the open metal clamp ⑤ and close the clamp.



Note

Make sure that the connection is leakproof!

14.2 Connecting the test gas line

- To connect the test gas line, a threaded tube connector with $\text{Ø } 6 \times 1 \text{ mm}$ (DN4/6) is available (see Figure 1)
- If you use a PTFE tube as sample line, a metal tubing sleeve for pneumatic fittings needs to be inserted at the end of the tube to prevent it of being pressed together.
- The temperature-resistant, stainless steel connector ④ from M&C has a double-blade ring system to ensure reliable sealing. First finger-tight the nuts of these connectors, then use a flat spanner to turn the nuts exactly $1\frac{1}{4}$ -turns. The nuts are now correctly mounted.



When selecting the gases or gas mixtures to be applied to the probe via the calibration adapter connection, reactions with the environment and the process must be excluded.

15 Electrical Connection



Warning

When connecting the equipment, make sure that the supply voltage is identical with the information provided on the model type plate.



Setting up of electrical power installations must be conform to the requirements of IEC 364 (DIN VDE 0100) 'Regulations on the Installation of Power Circuits with Nominal Voltages below 1000 V', and must be in compliance with all relevant regulations and standards.



Note

We recommend the use of temperature resistant cable! A main switch and matching fuse must be provided externally! The main circuit must be equipped with a fuse corresponding to the nominal current (over current protection); for electrical details see '8 Technical Data' on page 11. We recommend to use a low temperature alarm at all times. In case of an alarm the flow can be stopped and the components downstream of the probe will be protected.

The junction box is mounted on the side of the probe. The wiring plan is inside the lid of the junction box. Two separate cord grips are available for the mains and the signal cable.

Please follow the following steps to connect the equipment:

- Remove the lid of the junction box.
- Insert the power cord through the cord grip M20. Connect the mains cable to the appropriate terminals as shown below.
- Insert the signal cable through the other cord grip M16 and connect it to the appropriate terminals as shown in the wiring below.
- Tighten both cord grips to secure the inserted cables and prevent cable pull out.
- If you don't use a signal cable, the cord grip M16 needs to be closed with a hole plug (not included).
- Screw lid back on.

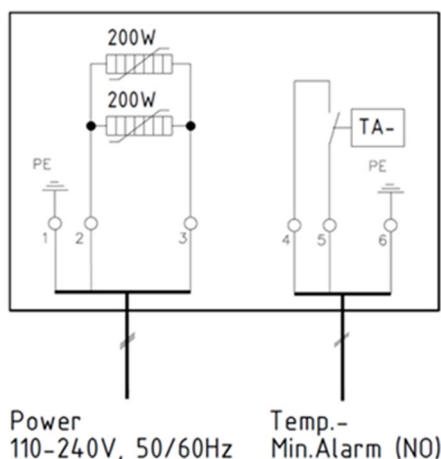

Figure 3 Electrical connection diagram

16 Starting up



Do not start-up the sample gas probe while potentially explosive atmosphere is present.

The process and the environment of the probe needs to be explosion-free (explosion-free zone) during start-up. A zone is declared as explosion-free zone, if it is free of explosive atmosphere.

Connect the probe to earth (electrical bonding terminal).

The bleeder resistor needs to have an overall value of $< 10^6 \Omega$. The protection cover does not need to be connected to earth. Following the maintenance procedure, the protection cover needs to be cleaned by damp cleaning wipes.

Make sure that the supply voltage matches the specified voltage on the product label of the probe, before connecting the device.

- Switch on mains power supply. The total heating-up time is approximately 2 hours. After about 1 hour the temperature of the probe is already higher than the temperature failure alarm value (160 °C [320 °F]), but it still takes about another hour until operation temperature has been reached.
- After the minimum heating-up time of 2 hours, the gas sample probe can start to extract the sample gas.

17 Maintenance

Before starting any maintenance work, please make sure that any work done on the device is in compliance with all relevant regulations and standards.



Warning

Disconnect power supply before opening the device for access.
Make sure that all external power supplies are disconnected.



This also applies to any external alarm or control circuits which may be connected.



Do not carry out any maintenance work at the sample gas probe while potentially explosive atmosphere is present. The process and the environment of the probe needs to be explosion-free (explosion-free zone) during maintenance. A zone is declared as explosion-free zone, if it is free of explosive atmosphere.



Warning

Inhalation hazard possible, if using toxic or asphyxiant gases!

Purge sample gas probe with inert gas or air before opening!

If the sample gas probe is used for toxic gas or asphyxiant (oxygen-displacing) gas, it needs to be purged with inert gas or air before opening. Follow closely all relevant occupational safety regulations during operation.



Warning

Connect the probe to earth (electrical bonding terminal).

The bleeder resistor needs to have an overall value of $< 10^6 \Omega$. The protection cover does not need to be connected to earth. Following the maintenance procedure, the protection cover needs to be cleaned by damp cleaning wipes.

The intervals between servicing are dependent on the process and system conditions in your facility. The facility QA/QC plan should address the frequency for maintenance and should be updated based on your operations.

An indication that maintenance work of the sample probe might be necessary, is a steady decrease of the amount of sample gas going out to your analysis system.

The routine maintenance work consists mainly of replacing filter elements and checking seals.



Warning

When working during operation: High surface temperatures!



Touching the device can cause severe burns!



Wear protective gloves! Secure the device against unauthorized access.

To start the maintenance work, please follow these steps:

- Remove insulation cap ① by squeezing and lifting the cap (see Figure 4).

Caution

Don't use the green retaining strap to remove the insulation cap. The insulation cap will be damaged by using the retaining strap!

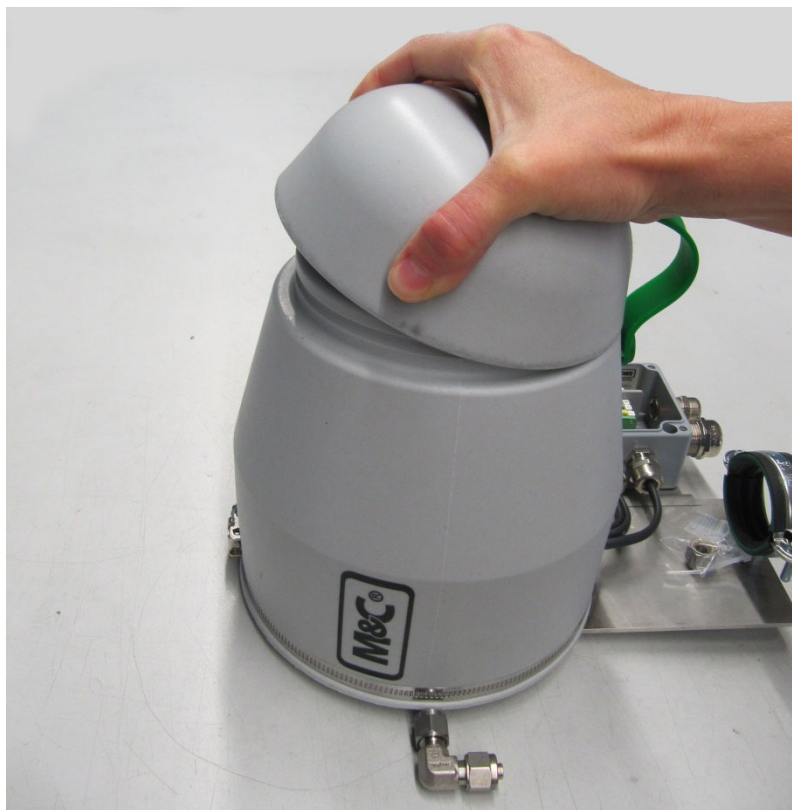

Figure 4 Opening of the insulation cap

- Loosen filter lid by turning handle ② to the left. Then pull out the filter lid with o-rings ③, filter element sealings ④, filter element ⑤ with filter element holder ⑦ and filter's knurled head thumb screw ⑥.



Warning

Electrostatic discharge possible!

Always clean the probe with a damp cloth to prevent electrostatic discharge (ESD).



Note

To remove the filter lid, please hold the filter lid clamp against the studs and turn the handle to the left until the filter lid loosens.

- Unscrew the knurled head thumb screw ⑥ of the filter and remove the filter element ⑤.
- Check the seals of the filter element ④ and replace if necessary.
- Check o-rings of the filter lid ③ and replace if necessary.
- Place new filter element ⑤ on the filter element holder ⑦.
- Screw-on the knurled head thumb screw ⑥ again.
- Clean the filter chamber. Now, while the filter lid with the filter element is removed, you can clean the inside of the probe tube to remove residue.
- To assemble the sample probe, please insert the filter lid with the new filter element back into the probe. To tighten the filter lid, put the filter lid clamp against the studs and turn the handle ② to the right.
- Place insulation cap back on the sample probe.

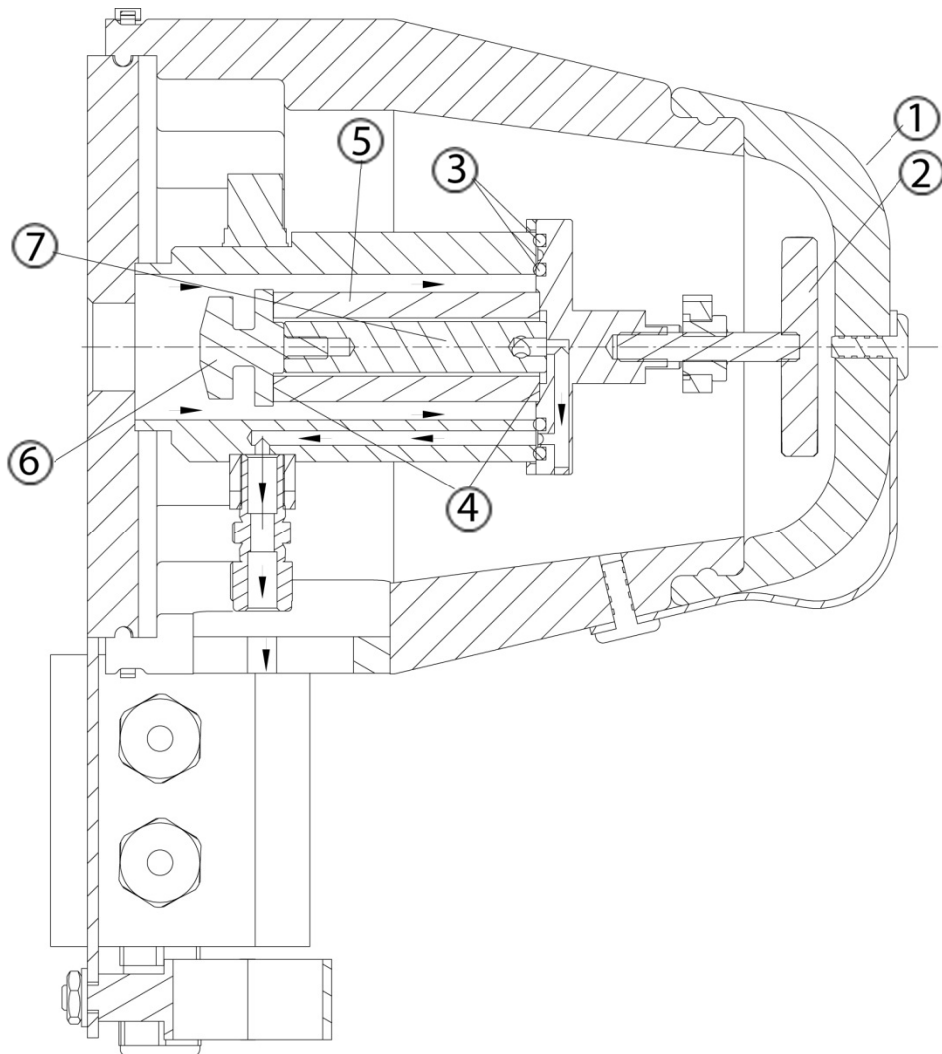

Figure 5 Replacing the filter element



18 Decommissioning

Flush gas sample probe with inert gas or air before decommissioning the gas sample probe (turning off the heating). This will prevent condensation of aggressive components of the process gas.

19 Spare parts and consumables

The replacement interval for spare parts and consumables depends on the specific operating condition of the probe. The quantities recommended in the following table are based on experience. Your replacement intervals will be based on your operating conditions.

Gas sample probe SP180-H-EX2 T*					
(C) Consumable parts					
(R) Recommended spare parts					
(S) Spare parts					
					recommended amount based on number of years of operation [years]
Part No.	Description	C/R/S	1	2	3
90S0015	Ceramic filter element S-2K, 2 µm, 75 mm [≈ 2.95"] ⑤	C	6	12	18
93S0045	Viton - gasket (30) ④	R	4	8	12
93S0020	O-ring lid sealing (39) Material: Viton®. ③	R	2	4	6
93S0025	O-ring lid sealing (55) Material: Viton®. ③	R	2	4	8
90S2080	Novapress® gasket 3/4" (blue), max. 600 °C [max. 1112 °F]	R	1	2	3
90S2077	Novapress® flange gasket DN65 PN6 (67 mm i.)	R	1	1	1
90S2075	Flange gasket set for DN65 PN6 B, consisting of Novapress® gasket (67 mm i.) and screws set M12	S	1	1	1
90S5060	HEX4/SP180-H Alarm switch Ex 135°C [275 °F]	R	-	-	1
90S5065	HEX4/SP180-H Alarm switch Ex 180°C [356 °F]	R	-	-	1
93S1810	Cartridge heater SP180 HLPSR, L = 100 mm [≈ 3.94"], 110-240 VAC 100 W	R	2	2	4

20 Appendix

- Type examination certificate



Further product documentation is available on our home page:

<http://www.mc-techgroup.com>

- Sample tubes series SP, Document: 2.14 and 2.15
- Prefilter series SP, Document: 2.7



Translation

Type Examination Certificate

Equipment or Protective System intended for use in potentially explosive atmospheres
Directive 2014/34/EU

Type Examination Certificate Number: **BVS 16 ATEX E 039**

Product: **Gas sampling probe Typ SP180 H-EX2 T2, SP180 H-EX2 T3, SP180 H-EX2 T4**

Manufacturer: **M&C TechGroup Germany GmbH**

Address: **Rehhecke 79, 40885 Ratingen, Germany**

This product and any acceptable variation thereto are specified in the appendix to this certificate and the documents therein referred to.

DEKRA EXAM GmbH certifies that this product has been found to comply with the Essential Health and Safety Requirements relating to the design and construction of products intended for use in potentially explosive atmospheres given in Annex II to the Directive.
The examination and test results are recorded in the confidential Report No. BVS PP 16.2108 EU.

Compliance with the Essential Health and Safety Requirements has been assured by compliance with:

EN 60079-0:2012 + A11:2013 General requirements
EN 60079-7:2015 Increased Safety "e"
EN 60079-18:2009 Encapsulation "m"

Except in respect of those requirements listed under item 18 of the appendix.

If the sign "X" is placed after the certificate number, it indicates that the product is subject to the Specific Conditions of Use specified in the appendix to this certificate.

This Type Examination Certificate relates only to the design and construction of the specified product. Further requirements of the Directive apply to the manufacturing process and supply of this product. These are not covered by this certificate.

The marking of the product shall include the following:

 **II 3G Ex ec mc IIC T2/T3/T4 Gc**

DEKRA EXAM GmbH
Bochum, 2016-06-09

Signed: Simanski

Certifier

Signed: Dr. Wittler

Approver



Page 1 of 3 of BVS 16 ATEX E 039
This certificate may only be reproduced in its entirety and without any change.

DEKRA EXAM GmbH, Dinnendahlstrasse 9, 44809 Bochum, Germany,
telephone +49.234.3696-105, Fax +49.234.3696-110, zs-exam@dekra.com



13 **Appendix**

14 **Type Examination Certificate**

BVS 16 ATEX E 039

15 **Product description**

15.1 **Subject and type**

Gas sampling probe type SP180 H-EX2 T2, SP180 H-EX2 T3, SP180 H-EX2 T4

15.2 **Description**

The Gas sampling probe is for dust filtration of measuring gas. It consists of a heating cartridge in type of protection Increased Safety and a temperature alarm in type of protection Encapsulation. Heating and temperature alarm are always covered by a metallic hood.

15.3 **Parameters**

15.3.1 **Electrical data**

Supply			
Supply voltage	110-240	V	
Frequency	50/60	Hz	
Power	200	VA	
Rated current	3.5	A	
Alarm contact			
Voltage	250	V	
Current	AC 1.5	A	
	DC 0.5	A	

Thermal data

Ambient temperature -20 °C...80 °C

Temperature class

Temperature class	Service temperature [°C]	Max. power heating cartridge [°C]
T2	180	240
T3	155	180
T4	100	130

16 **Report Number**

BVS PP 16.2108 EU, as of 2016-06-09

17 **Special Conditions for Use**

None

18 **Essential Health and Safety Requirements**

The Essential Health and Safety Requirements are covered by the standards listed under item 9.

19 **Drawings and Documents**

Drawings and documents are listed in the confidential report.



Page 2 of 3 of BVS 16 ATEX E 039
This certificate may only be reproduced in its entirety and without any change.

DEKRA EXAM GmbH, Dinnendahlstrasse 9, 44809 Bochum, Germany,
telephone +49.234.3696-105, Fax +49.234.3696-110, zs-exam@dekra.com



We confirm the correctness of the translation from the German original.
In the case of arbitration only the German wording shall be valid and binding.

DEKRA EXAM GmbH
Bochum, dated 2016-06-09
BVS-Pe/Nu A 20160233

Certifier

Approver

