

Oxygen – Analyzer Series PMA[®]

PMA 30/D, PMA 30/A/D

Instruction Manual
Version 1.01.03



**Dear customer,**

Thank you for buying our product. In this manual you will find all necessary information about this M&C product. The information in the manual is fast and easy to find, so you can start using your M&C product right after you have read the manual.

If you have any question regarding the product or the application, please don't hesitate to contact M&C or your M&C authorized distributor. You will find all the addresses in the appendix of this manual.

For additional information about our products and our company, please go to M&C's website www.mc-techgroup.com. There you will find the data sheets and manuals of our products in German and English.

This Operating Manual does not claim completeness and may be subject to technical modifications.

© 04/2023 **M&C TechGroup** Germany GmbH. Reproduction of this document or its content is not allowed without permission from **M&C**.

With the release of this version all older manual versions will no longer be valid. The German instruction manual is the original instruction manual. In case of arbitration only the German wording shall be valid and binding.

PMA[®] is a registered trade mark.

Version: 1.01.03

Content

1	General information	5
2	Declaration of conformity	5
3	Safety instructions	6
4	Warranty	6
5	Used terms and signal indications	7
6	Introduction	8
6.1	Serial number	8
6.2	Power supply	8
7	Application	8
8	Technical data	9
8.1	Options	10
9	Description	11
9.1	Front panel	12
9.2	Option process pressure compensation type PD (without SIL certification)	13
9.3	Option zero suppression with process pressure compensation type SD/PD (without SIL-certification)	13
10	The measuring principle	13
11	Gas flow diagram of the analyzer PMA 30	14
12	Receipt of goods and storage	15
13	Installation	16
13.1	Connection of Sample gas inlet and sample gas outlet	16
13.2	Standard gas conditioning system	17
13.3	Electrical connection	17
13.3.1	Analog signal output	18
13.3.2	Description 0/4-20mA outlet	19
13.3.3	Adjustment of the current signal outlet	19
13.3.4	Adjustment of the load	19
13.3.5	Adjustment of the max. current signal at the mA-outlet	19
13.3.6	Description 0-10 V outlet	20
13.3.7	Status signal	20
13.3.8	Remote range control and External measuring range indication	21
14	Starting up	22
15	Calibration	22
15.1	Zero calibration	22
15.2	Span calibration	24
16	Measuring	25
17	Cross sensitivities	27
18	Closing down	30
19	Storage and Transport	30
20	Maintenance	30
20.1	Removal of the measuring cell	31
20.2	Mechanical zero point adjustment	33
21	Trouble shooting	35
22	Proper disposal of the device	36
23	Spare parts list	36
24	Appendix	37

List of Illustrations

Figure 1	Dimensions PMA30	11
Figure 2	Front panel PMA 30.....	12
Figure 3	Scheme of the measuring cell and optical signal processing.....	14
Figure 4	Gas flow diagram PMA 30.....	14
Figure 5	Standard gas conditioning system	17
Figure 6	Back side PMA 30.....	18
Figure 7	Pin assignment of D-sub-connector X4	20
Figure 8	Pin assignment of D-sub-connector X1	21
Figure 9	Transmitter unit.....	32
Figure 10	Schematic view of the transmitter unit	34
Figure 11	Circuit diagram PMA30 main board	40
Figure 12	Assembly diagram PMA 30 main board.....	41
Figure 13	Circuit diagram PMA 30 front board	43
Figure 14	Assembly diagram front board PMA 30.....	44
Figure 15	Circuit diagram extension board PMA 30.....	45
Figure 16	Assembly diagram extension board PMA 30	46
Figure 17	Connections wall mounting housing PMA 30.....	47
Figure 18	PMA 30 in wall mounting housing.....	48

HEAD OFFICE

M&C TechGroup Germany GmbH ♦ Rehhecke 79 ♦ 40885 Ratingen ♦ Germany

Telephone: 02102 / 935 – 0

Fax: 02102 / 935 – 111

E - mail: info@mc-techgroup.com

www.mc-techgroup.com

1 GENERAL INFORMATION

The product described in this operating manual has been examined before delivery and left our works in perfect condition related to safety regulations. In order to keep this condition and to guarantee a safe operation, it is important to heed the notes and prescriptions made in this operating manual. Furthermore, attention must be paid to appropriate transportation, correct storage, as well as professional installation and maintenance work.

All necessary information a skilled staff will need for appropriate use of this product are given in this operating manual.

2 DECLARATION OF CONFORMITY



The product described in this operating manual complies with the following EU directives:

EMV-Instruction

The requirements of the EU directive 2014/30/EU "Electromagnetic compatibility" are met.

Low Voltage Directive

The requirement of the EU directive 2014/35/EU "Low Voltage Directive" are met.
The compliance with this EU directive has been examined according to DIN EN 61010.

Declaration of conformity

The EU Declaration of conformity can be downloaded from the **M&C** homepage or directly requested from **M&C**.

The SIL – Declaration of conformity can be directly requested from **M&C**

Electrical equipment standard

The electrical equipment standard meets the safety requirements of the following norms and standards: EN 61010.



3 SAFETY INSTRUCTIONS

Please take care of the following basic safety procedures when mounting, starting up or operating this equipment:

Read this operating manual before starting up and use of the equipment. The information and warnings given in this operating manual must be heeded.

Any work on electrical equipment is only to be carried out by trained specialists as per the regulations currently in force.

Attention must be paid to the requirements of VDE 0100 (IEC 364) when setting high-power electrical units with nominal voltages of up to 1000 V, together with the associated standards and stipulations.

Check the details on the type plate to ensure that the equipment is connected to the correct mains voltage.

Protection against touching dangerously high electrical voltages:

Before opening the equipment, it must be switched off and hold no voltages. This also applies to any external control circuits that are connected.

The device is only to be used within the permitted range of temperatures and pressures.

Check that the location is weather-protected. It should not be subject to either direct rain or moisture.

The device must not be used in hazardous areas.

Installation, maintenance, monitoring and any repairs may only be done by authorized personnel with respect to the relevant stipulations.

4 WARRANTY

If the equipment fails, please contact **M&C** directly or else go via your appointed **M&C** dealer.

We offer a one year warranty as of the day of delivery as per our normal terms and conditions of sale and assuming technically correct operation of the device. Consumables are hereby excluded. The terms of the warranty cover repair at the factory at no cost or the replacement at no cost of the equipment free ex user location. Reshipments must be sent in a sufficient and proper protective packaging.



5 USED TERMS AND SIGNAL INDICATIONS



DANGER!

This means that death, severe physical injuries and/or important material damages **will occur** in case the respective safety measures are not fulfilled.



WARNING!

This means that death, severe physical injuries and/or important material damages **may occur** in case the respective safety measures are not fulfilled.



CAUTION!

This means that minor physical injuries **may occur** in case the respective safety measures are not fulfilled.

CAUTION!

Without the warning triangle means that a material damage may **occur** in case the respective safety measures are not met.

ATTENTION

This means that an unintentional situation or an unintentional status **may occur** in case the respective note is not respected.



NOTE!

These are important information about the product or parts of the operating manual which require user's attention.

SKILLED STAFF

These are persons with necessary qualification who are familiar with installation, use and maintenance of the product.



High voltages!
Protect yourself and others against damages which might be caused by high voltages.



Hot surface!
Contact may cause burn! Do not touch!



Wear protective gloves!
Working with chemicals, sharp objects or extremely high temperatures requires wearing protective gloves.



6 INTRODUCTION

The **M&C** oxygen analyzer **PMA 30** is a temperature-controlled instrument which has been designed for continuous measurements of oxygen concentrations in particle free and dry sample gas.

6.1 SERIAL NUMBER

The type plate with the serial number is on the back of the analyzer.

Whenever you call **M&C** regarding questions or orders for the spares please give us the serial number of your **PMA 30**.

6.2 POWER SUPPLY

The power supply of the oxygen analyzer **PMA 30** is 115 V or 230 V AC, 40–60 Hz. The specification is on the type plate. Variations of the power supply of $\pm 15\%$ have no influence on the functionality of the analyzer.

7 APPLICATION

The Oxygen Analyzer **PMA 30** is suitable for the continuous measurement of oxygen in particle-free and dry sample gases with a maximum dew point of 5 °C.

The features of the analyzer are safe operation, accuracy and low maintenance.

The measurement is based on the physical principle of the magneto-dynamic oxygen measuring cell and is one of the most exact quantitative methods of oxygen determination within the range of 0-100 vol% oxygen.

There is a direct flow against the measuring cell which has got a low volume of only 2 ml (small stagnant volume). Further characteristics are robustness, extremely small drift, fast response time ($T_{90} < 3$ sec.) and negligible cross sensitivities to other sample gas components.

Fluctuations of the sample gas flow in a range from 10 to 60 NI/h nitrogen (N_2) cause a change of the oxygen reading which is smaller than 0.1 vol% O_2 .

Measurements in flue gases and in inerting plants are some typical applications for the **PMA 30** within a great variety of other measurement tasks.

8 TECHNICAL DATA

Oxygen analyzer Series PMA®	Version PMA 30/D, PMA 30A/D
Part No. 03A2005 03A2005a 03A2001 03A2005a	PMA 30/D 230 V 50 Hz, PMA 30/D 115 V 60 Hz, PMA 30A/D 230 V 50 Hz, PMA 30A/D 115 V 60 Hz
Power supply	230 V AC (standard) or 115 V AC available (a)* ±15 %, 40-60 Hz, 35.5 VA
Electrical connections	Power: 3-pole mains plug with 2 m cable; signals: 9 and 25 pole plug
Measuring ranges	Selectable for 0-1, 0-3, 0-10, 0-30 and 0-100 vol% O ₂ , linear
External measuring range indication	One potential free contact for each selected range, Contact rating max. 48 V DC, 0.2 A Min. contact load 5 V/1 mA
Remote range control	Remote range control for all 5 ranges by means of external potential free contacts max. 30 V DC 3 mA DC. (requirement: selection switch in position Ext.)
Indication	PMA 30A/D: analogue meter with a scale of 0-30 and 0-100 % for each selected range, digital meter, 4 1/2 digit 9 mm high for 0-100 % O ₂ reading, resolution 0.01 vol% O ₂ PMA 30/D : digital meter, 4 1/2 digit 18 mm high for 0-100 % O ₂ reading, resolution 0.01 vol% O ₂
Output signal	0-20/4-20 mA* for the chosen range, non-isolated, max. load 300 Ω Output voltage max. 15 V (delivered condition). Switchable to a load of max. 900 Ω output voltage max. 30 V. Output current limiting adjustable 20.5 mA – 22 mA. Delivered condition 21 mA. 0-1 V DC, load > 100 kΩ, for the range of 0-100 vol%
Response time for 90% FSD	< 3 seconds at 60 NI/h air
Accuracy after calibration	±1 % of the span value of measuring range after calibration or ±0.02 % O ₂ depending on which value is the higher one
Reproducibility deviation	Deviation: analogue = < 1% of span/digital = ±0.1 vol% O ₂
Reproducibility deviation without changing the measuring range**	Analog output without changing measuring range** = < 0.1 % of measuring range / digital reading = ± 0.01 vol% O ₂
Influence of ambient temperature	No influence up to 45 °C
Influence of barometric pressure	The oxygen reading varies in direct proportion to changes of the barometric pressure.
Influence of sample gas flow	Fluctuations of the sample gas flow in a range from 10 to 60 NI/h nitrogen (N ₂) cause a change of the oxygen reading which is smaller than 0.1 vol% O ₂
Sample gas inlet pressure	0.01 up to 1 bar g, (PMA 30 required admission pressure for competent flow rate, no pump inside)
Sample gas outlet pressure	Outlet of analyzer must discharge freely into atmosphere.
Flow rate of sample gas	Min. 10 to max. 60 NI/h, adjustable with needle valve on the flowmeter (flowmeter is calibrated for air and has a measuring range of 7-70 NI/h)
Temperature of sample gas	-10 °C up to +50 °C, dry gas
Analyzer temperature	Fixed at +55 °C
Ambient temperature	-10 °C up to +45 °C
Storage temperature	-20 °C up to +60 °C, relative humidity 0-90% RH
Power supply	Internal power unit for 230 V AC standard or 115 V AC available (a)* ±15 %, 40-60 Hz, 35.5 VA
Electrical connections	Mains supply: 3-pole chassis plug with 2 m of cable; signals: 7, 9 and 25-pole plugs

Oxygen analyzer Series PMA®	Version PMA 30/D, PMA 30A/D
Materials in contact with sample gas	Platinum, Glass, PTFE, PVDF, Stainless Steel 316Ti, FKM, Epoxy resin
Sample gas connection	1/8" NPT i
Flow alarm	thermo-conductive flow sensor downstream mounted after measuring cell
Status alarm	2 x change over contact, potential free, max. 48 V DC, 0.5 A (min. switching capacity 50 mW) for flow min-max.-fault, transmitter temperature < 45 °C >60 °C, light source defective, coupling state, measuring range exceeding, range selection switch defective, power supply error, mains voltage breakdown (12 times internal LED-indication)
Protection / electrical standard	IP 20 EN 60529 / EN 61010
Housing / colour	3U/28HP - 19-inch cassette European standard/silver
Dimension / weight	Height 3U, width 28HP, length 230 mm + approx. 60 mm installation space / approx. 2.5 kg

* Please specify with order.

**The minimized error of < 0.1 vol% for the reproducibility deviation can only be selected if the measurement and calibration ranges are identical. If the instrument is switched to another measuring range, a value of < 1 % of the measuring range is to be expected.

8.1 OPTIONS

Options	
03A9165	Extra charge for PMA 30 as solvent resistant execution with measuring cell type PMC-1LB. Material: O-rings out of Kalrez.®
02A9005	Extra charge for PMA 20/30 in chlorine resistant execution with a special measuring cell type PMC-1CL2. All gas bearing tubes PTFE/PVDF equipped with purge gas connectors.
03A9535	Extra charge for electrical zero suppressing with process pressure compensation type SD/PD for PMA30, pressure range ± 0.6 bar, media wetted parts: stainless steel, PVDF, FKM. Not with SIL-certification!
03A9530	Extra charge for process pressure compensation type PD for PMA30, pressure range ± 0.6 bar, media wetted parts: stainless steel, PVDF, FKM. Not with SIL-certification!
03A9150	Wall mount housing out of aluminum type 30-19 with 19"-insertion system (3U/42TE), incl. clamp box, clamp boards and filter, with window. protection class: IP65.
01A9165	Extra charge for changed measuring range to 2.5/5/10/25/100 vol% O ₂ , for recorder outlet and digitalmeter (only for PMA30/D).

9 DESCRIPTION

The **PMA 30** is a reliable and easy-to-operate instrument. It is built into a compact 19-inch cassette. The transducer unit maintains a constant operating temperature of 55 °C and a flashing LED on the control panel indicates the proper operating temperature of the analyzer. The five measuring ranges are displayed on the analogue meter with 30 and 100 % scale. Two output signals are available. Sample gas connections as well as connectors for incoming power supply, output signals, remote ranging, remote range indication and status contact are located at the rear panel of the analyzer. The sample gas enters the analyzer via an external protective fine filter. The required flow rate can be adjusted at the flowmeter with needle valve, mounted on the front panel upstream the **M&C** measuring cell and the flow alarm sensor. The internal tubing is made of PTFE and PVDF.

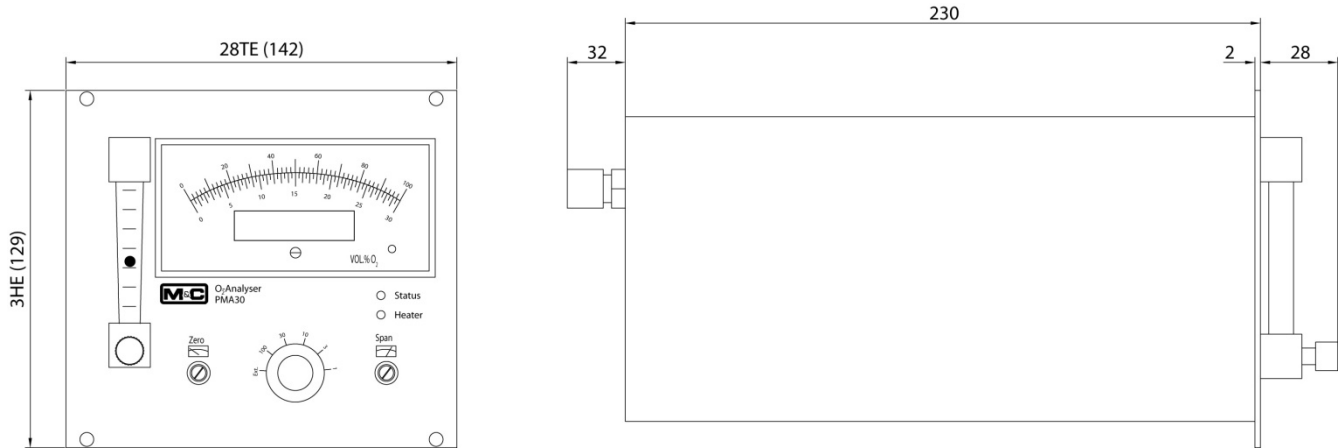
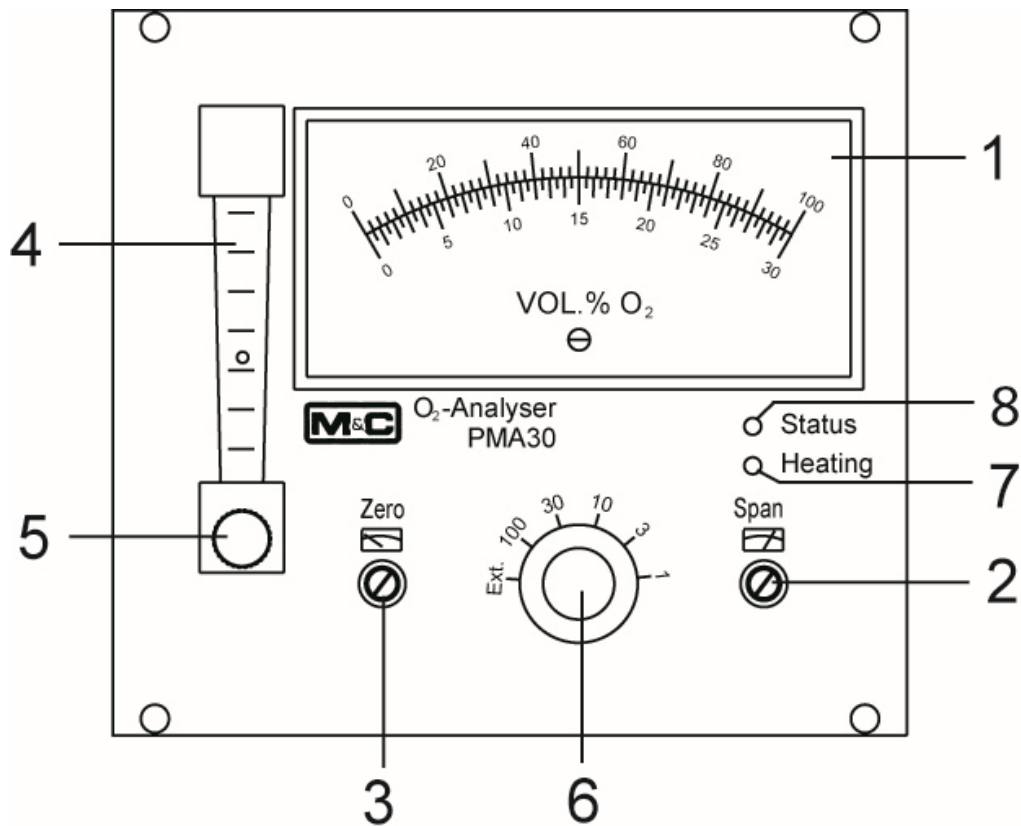

Figure 1 Dimensions PMA30

9.1

FRONT PANEL



- | | | | |
|----------|--------------------|----------|---------------------------------|
| 1 | Analog indication | 5 | Needle valve 7 - 70 NI/h |
| 2 | Zero potentiometer | 6 | Measuring range selector switch |
| 3 | Span potentiometer | 7 | LED - heating control |
| 4 | Flow meter | 8 | LED - alarm status |

Figure 2

Front panel PMA 30

9.2 OPTION PROCESS PRESSURE COMPENSATION TYPE PD (WITHOUT SIL CERTIFICATION)

In case of barometric or process originated pressure variations, the **PMA 30** can be equipped with a special pressure compensation. The compensation can be effected within a pressure range of 0.6 – 1.6 bar abs.. Thereby errors in measurement caused by pressure variations can be eliminated.

The pressure compensation can alternatively be switched on or off separately for indications and signal outlet :

- Digital indication via jumper JP1 on the front board (see figure 13 and 14)
- 0-10 V signal outlet via jumper JP1 on the main board (see figure 12 and page 39)
- Analog indication and 20mA current signal via jumper JP2 on the main board (see figure 12 and page 39)

9.3 OPTION ZERO SUPPRESSION WITH PROCESS PRESSURE COMPENSATION TYPE SD/PD (WITHOUT SIL-CERTIFICATION)

A zero-suppression acting on the measuring range dependent elements analog indication and 20mA current signal is possible in 1% steps for devices with pressure compensation within a range of 1 % to 97 % O₂. The factory provided adjusted suppression can be assigned to one or more measuring ranges via jumper JP1 on the extension board (see figure 15 + 16).

A suppression of 97 % via jumper JP1 pos. 3 combined with the 3 % measuring range results in the new measuring range: 97 %-100 %.

10 THE MEASURING PRINCIPLE

Oxygen is a gas with a significant paramagnetic susceptibility. The molecules of oxygen are attracted much more strongly by a magnetic field than the molecules of other gases.

The measuring principle shown in the following is benefitting from these characteristics of the oxygen. The great advantage of the paramagnetic measuring principle is the highly reduced cross sensitivity of the measurement to other components in the sample gas.

Figure 3 shows the diagram of the measuring cell as well as the optical system for the detection of the dumb-bell's movement.

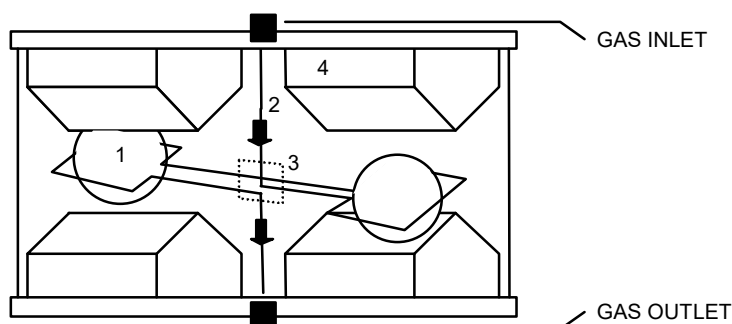

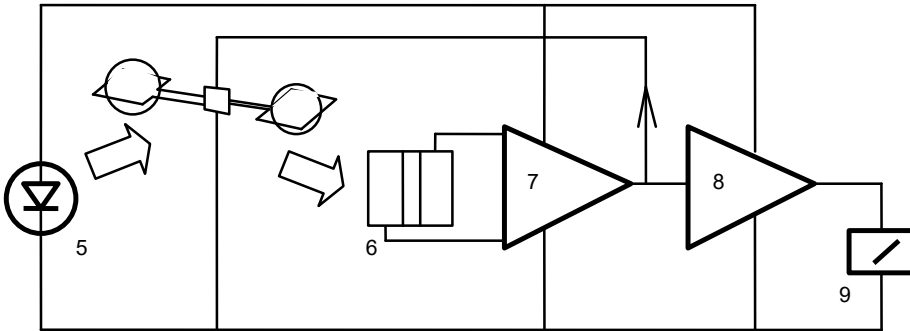

Figure 3 Scheme of the measuring cell and optical signal processing

The measuring cell consists of two nitrogen-filled spheres ① which are arranged in the form of a dumbbell. In the dumbbell's central point of rotation, a small mirror ③ is placed. The dumbbell is surrounded by a wire coil needed for the compensation procedure. The described system is fixed rotationally symmetrical inside a glass tube via a tightening strap out of platinum ② and is screwed with two pole pieces ④.

Two permanent magnets are producing an inhomogeneous magnetic field. When oxygen is flowing in, the molecules of the oxygen are drawn into the magnetic field. In consequence, the lines of electric flux on the cuneiform pole pieces ④ are compressed. The nitrogen-filled diamagnetic spheres are pushed out of the magnetic field. This causes a rotation of the dumbbell. The rotation is detected via an optical system consisting of mirror ③, projection LED ⑤ and photoelectric cell ⑥.

In case the dumbbell is pushed out of the magnetic field, the tension of the photoelectric cell is immediately changed. The measuring amplifiers ⑦ and ⑧ are producing a respective current which develops via the wire coil on the dumbbell an electro-magnetic load moment. The load moment is resetting the dumbbell into its zero position.

Every change of the oxygen concentration produces a linear proportional change of the compensation current and can be read directly in % O₂ as oxygen value on the display ⑨.

Due to its very small stagnant volume (2 cm³) and the direct flow of the **M&C** measuring cell, an extremely fast response time (T₉₀-time) of 1 second for a high gas flow can be realized.

11 GAS FLOW DIAGRAM OF THE ANALYZER PMA 30

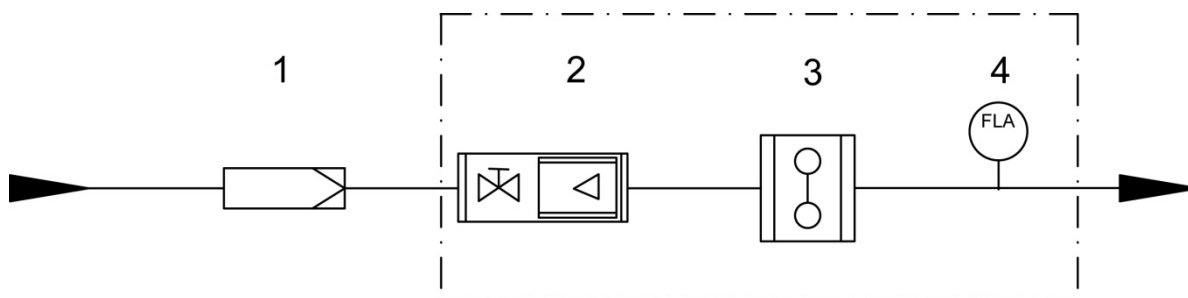

- ① Fine filter
- ② Flow meter with needle valve
- ③ Measuring cell
- ④ Flow alarm sensor

Figure 4 Gas flow diagram PMA 30

The measuring cell **3** must absolutely be protected against dust particles. Therefore, the preceding external gas conditioning system should be equipped with a fine filter **1** of at least 2 micron filter porosity (eg. type **FP-2T**).

The maximum gas flow of 60 NI/h is adjusted via flow meter **2** with needle valve on the front plate.

A flow sensor **4** in the outlet of the measuring cell is controlling the gas flow through the cell according to the measuring principle of thermal conductivity. In case the minimum gas flow is decreased, an alarm is automatically given and is available as status message on the the collective status output. Furthermore, an alarm state is shown by a colour change of the LED **8** (see figure 2) on the front plate of the analyzer (red/green).

12 RECEIPT OF GOODS AND STORAGE

The analyzer **PMA 30** is a completely pre-installed unit.

- Please take the analyzer and possible special accessories carefully out of the packaging material immediately after arrival, and compare the goods with the items listed on the packing list;
- Check the goods for any damage caused during delivery and, if necessary, notify your transport insurance company without delay of any damage discovered.



NOTE!

The oxygen analyzer PMA 30 must be stored in a weather-protected and frost-proof area!

13 INSTALLATION

The **PMA 30** is intended for stationary operation. In combination with a gas conditioning according to the requirements a long-lasting operability and a minimum of maintenance is guaranteed.



CAUTION!

The sample gas must be dust free and dry to prevent a contamination and condensation in the analyzer.

Basically, always connect a fine filter (e.g. type FP-2T, Part No. 01F1200) upstream.



CAUTION!

In case of outdoor operation protect the analyzer against sun, wind and rain.

At the installation location constant climatic ambient conditions (pressure, temperature) are necessary to prevent a distortion of the measurement and a condensation in the measuring cell in case the ambient temperature is falling below the dew point temperature of the sample gas. A vibration-free location is ideal for mounting; if this is not possible, appropriate measures must be taken. The analyzer must not be installed in direct proximity of heat sources.

The position of operation is not necessarily horizontal.



DANGER!

The analyzer is allowed to be operated only in non-hazardous areas and with non-ignitable gases and gas mixtures.

The analyzer is designed for 19"-rack mounting. It has to be fixed at the 4 exterior holes in the front panel with adequate screws.



NOTE!

Leave enough space at the back side of the analyzer for unrestricted electrical and pneumatic connections.

13.1 CONNECTION OF SAMPLE GAS INLET AND SAMPLE GAS OUTLET

The sample gas inlet and outlet are placed at the back side of the analyzer and have a 1/8" NPT i thread. Screw in here adequate tube connectors e.g. 1/8" NPT o – DN4/6 PVDF (Part No. 05V2045).

- Connect the sample gas inlet with a corresponding gas conditioning with e.g. a PTFE hose DN4/6.

ATTENTION

Sample gas has to discharge freely to atmosphere at the sample outlet because because an increase of pressure will distort the oxygen indication.

Do not bend the connection hoses.

13.2 STANDARD GAS CONDITIONING SYSTEM

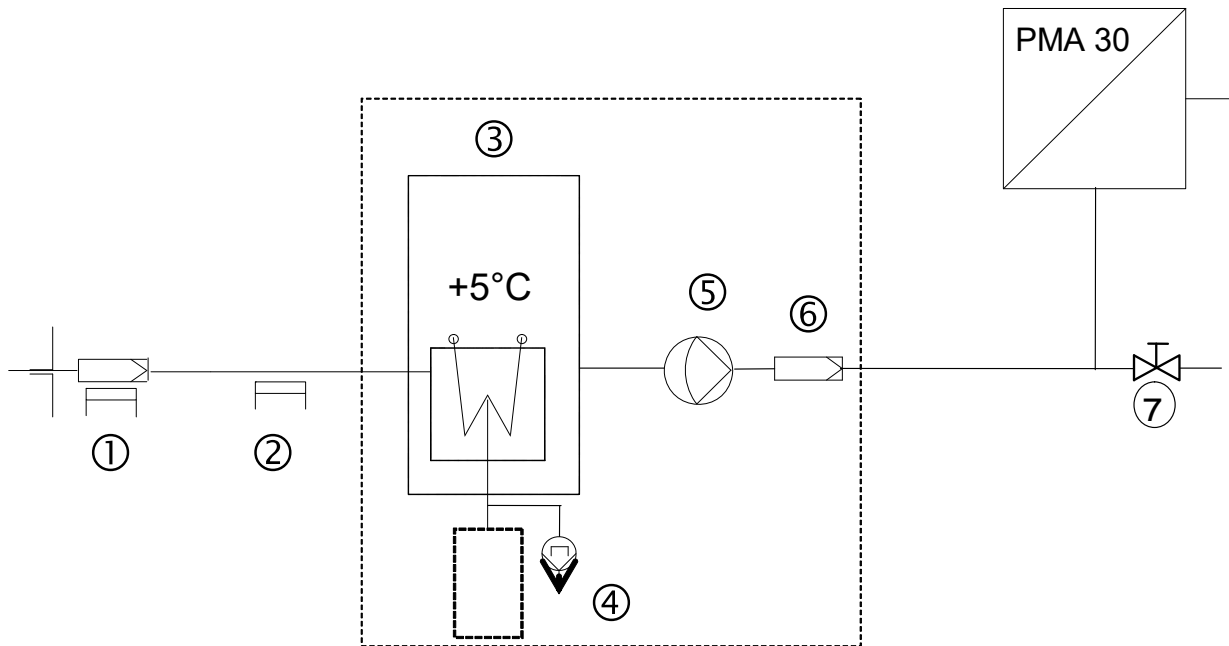

Figure 5 Standard gas conditioning system

- 1 : Heated gas sample probe (e.g. probe SP2000-H)
- 2 : Heated gas sample line (e.g. 4M4/6)
- 3 : Sample gas cooler (e.g. ECM-1G)
- 4 : Peristaltic pump or condensate collecting vessel (e.g. SR25.1 or TG-1)
- 5 : Diaphragm pump (e.g. N3)
- 6 : Fine filter (FP-2T)
- 7 : Bypass (e.g. FM40/250)

13.3 ELECTRICAL CONNECTION



CAUTION!

False supply voltage can damage the equipment. When connecting the equipment, please ensure that the supply voltage is identical with the information provided on the model type plate!

A mains connector plug is located at the back side of the analyzer housing. In the scale of delivery a 2 m connection cable with mains connector and earthing type plug is included.

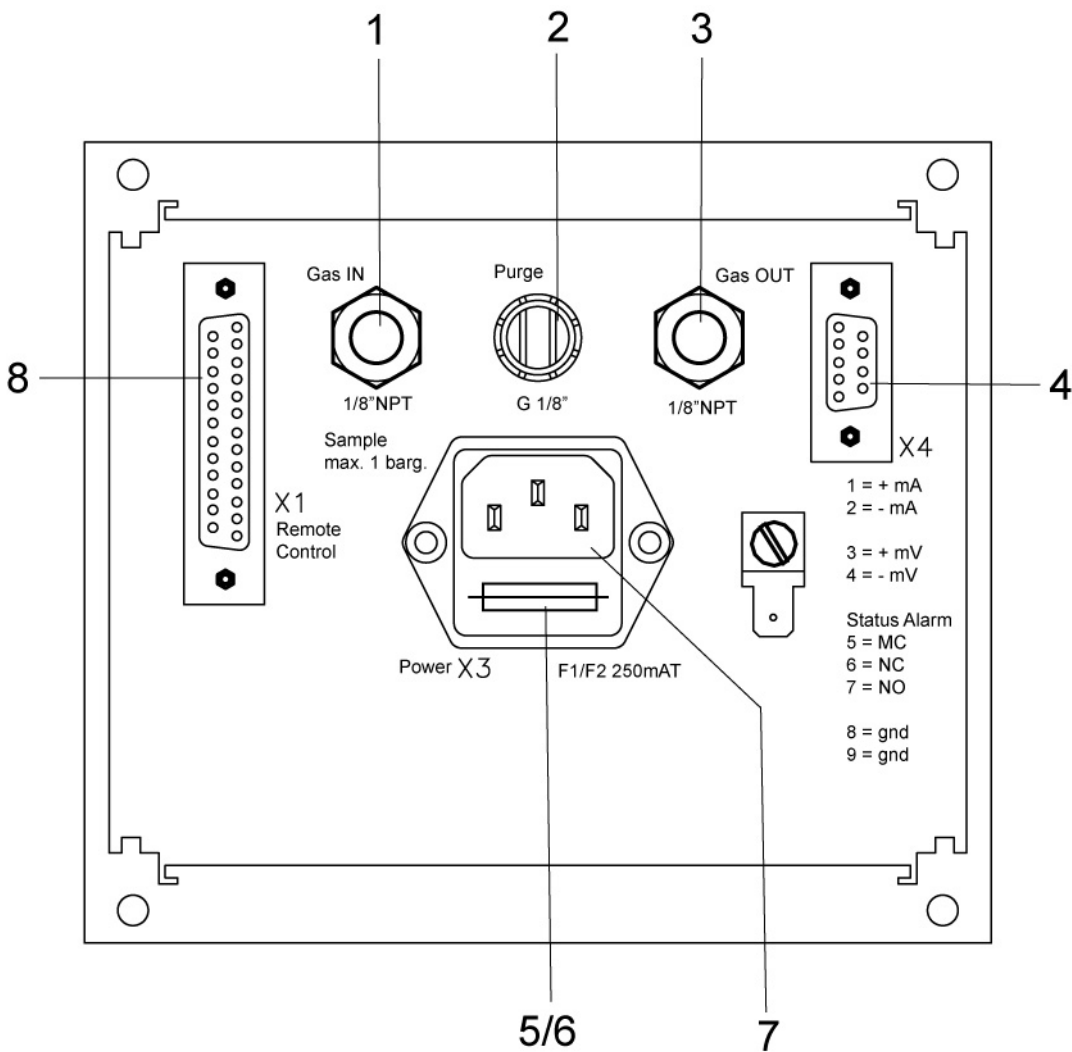

- 1 = Gas IN 1/8" NPTi
- 2 = Option purge gas connection 4/6
- 3 = Gas OUT 1/8" NPTi
- 4 = D-Sub-connector 9-pole for signal outlet

- 5/6 = Mains fuses (L and N)
- 7 = Mains IN / connector plug
- 8 = D-Sub-connector 25-pole for remote control and indication

Figure 6 Back side PMA 30

13.3.1 ANALOG SIGNAL OUTPUT

The **PMA 30** has two analog signal outputs as standard. A current signal optionally 0 or 4-20 mA and a voltage signal 0-10 V, both indicate up to 10 % above the corresponding measuring range. These analog signals contain initially no status signals.



NOTE!

By series connection of status contact and 4-20mA outlet failure information can be integrated.

13.3.2 DESCRIPTION 0/4-20MA OUTLET

- Every measuring range meets 0/4-20 mA (standard measuring ranges: 0-1 %; 0-3 %; 0-10 %; 0-30 %; 0-100 % O₂)
- Current range switchable (see 13.3.3; 4-20 mA standard factory setting)
- Galvanically isolated (internal power supply)
- For a max. load of 300 Ω in standard factory setting (max. 7 V); switchable to a max. load of 900Ω (max. 22 V)
- A max. limit of 20.5–23 mA is adjustable (see 13.3.5; 21 mA standard factory setting)
- A min. limit for 0-20 mA is at 0 mA resp. for 4-20 mA at 2.9 mA
- Linear range from 0 to 22 mA resp. 3.2 to 22 mA

General evaluation of the 0-20 mA signal:

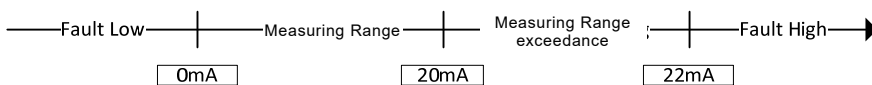

General evaluation of the the 4-20 mA signal:

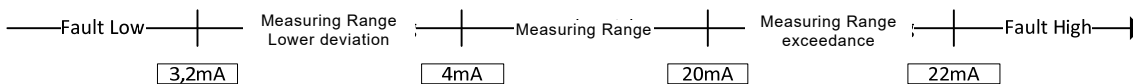

If the oxygen measurement is used as a safety function according to SIL the 4-20mA signal has to be evaluated as follows:

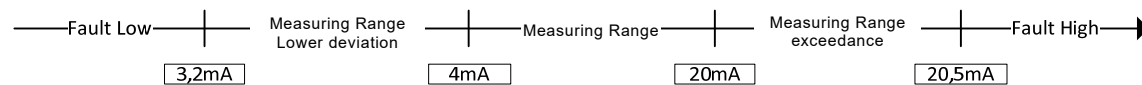

Current limiting occurs here when the current is ≥ 21 mA.

13.3.3 ADJUSTMENT OF THE CURRENT SIGNAL OUTLET

The range of the mA current signal can be switched via jumper JP13 and JP15 on the main board.
0-20 mA: JP13, JP15 in position 2-3; 4-20 mA: JP13, JP15 in position 1-2 (see figure 12).

13.3.4 ADJUSTMENT OF THE LOAD

Via jumper JP9 on the main board the load will be adjusted.
Max. 300 Ω: position 1-2 (standard); max. 900 Ω: position 2-3 (see figure 12).

13.3.5 ADJUSTMENT OF THE MAX. CURRENT SIGNAL AT THE MA-OUTLET

For adjustment of the max. output current:

- E.g. introduce air into the analyzer (20.9 % O₂) and switch to the 10%-measuring range This way you get the max. output signal.
- Measure current at D-sub-connector X4, pin 1 and 2
- Adjust desired max. current at potentiometer P1 on main board (see figure 12)

13.3.6 DESCRIPTION 0-10 V OUTLET

- 0-10 V always correspond to 100 % O₂ independent of the measuring range
- For a load of > 100 KOhm
- Linear from -0.5 V to 11 V

General evaluation of the 0-10 V signal:

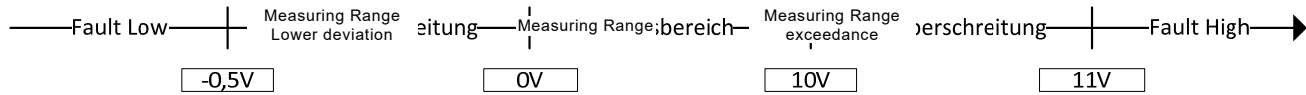

The connection happens at the 9-pole D-sub-connector X4. (see figure 6 and 7)

13.3.7 STATUS SIGNAL

The status signal contains a collective fault message:

- Power supply error, voltage breakdown
- Flow min. fault
- Flow max. fault (can be switched off: JP3)
- Light source short circuit/line breakage
- Selection switch defective
- Transmitter temperature < 45 °C/> 60 °C (can be switched off: JP8/JP7, 2+3 on, 1+2 off)
- Coupling state (can be switched off: JP6, 2+3 off, 1+2 on)
- Fault High/Fault Low (connectible: JP14/JP12). Measuring range lower deviation and exceedance more than +3.125 % resp. -4.375 %, (corresponds to > 20.5 mA resp. < 3.2 mA)

An allocation of the existing failures is possible via 12 internal LED's on the main board (see figure 12). The board becomes visible after removing the cover plate. To do this remove the two screws in the lid.

The status signal is accessible via a potential free switching contact (status contact) as well at X1 (D-sub 25-pole) as also at X4 (D-sub 9-pole) (see figure 6 and 7).

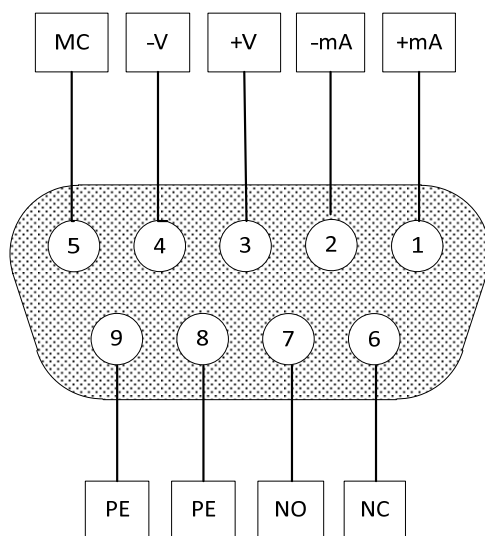

Figure 7 Pin assignment of D-sub-connector X4

13.3.8 REMOTE RANGE CONTROL AND EXTERNAL MEASURING RANGE INDICATION

The 25-pole D-sub-connector X1 (see figure 8) allows the connection for the remote range control. For release of this remote range control the measuring range selection switch at the front panel of the PMA30 (see figure 2, no. 6) has to be turned into position "Ext.".

The connections are potential separated.

In case of multiple range triggering the priority of measuring range choice is determined as:

Priority high	1 %,	3 %,	10 %,	30 %,	100 %	Priority low
X1:	Pin 8	Pin 9	Pin 10	Pin 11	Pin 12	Jointly: Pin 13

If no measuring range via X1 is triggered and the measuring range selection switch at the front panel of the PMA30 is in position „Ext.“, the 1 % measuring range is selected.

The external measuring range indication happens for the active measuring range via potential free contacts also at X1.

Measuring range	1 %,	3 %,	10 %,	30 %,	100 %	
X1:	Pin 5	Pin 4	Pin 3	Pin 2	Pin 1	Jointly: Pin 6

Figure 8 shows a circuit for indication of the measuring range indication with LED's.

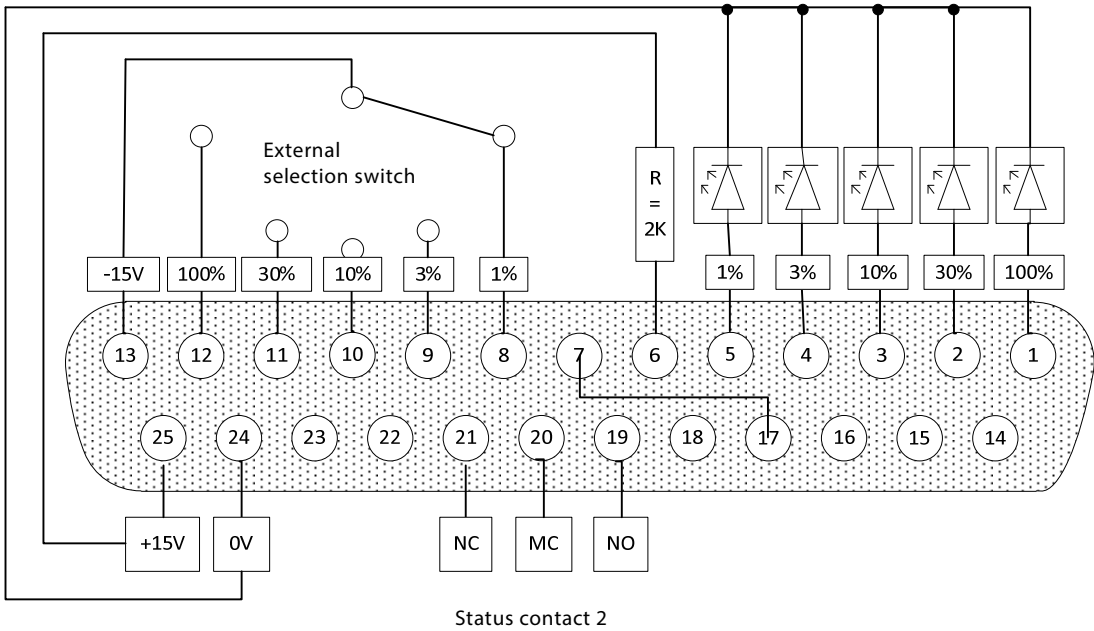

Figure 8 Pin assignment of D-sub-connector X1

The used voltage supply at pin 13, pin 24 and pin 25 is potential separated. The max. load current is 25 mA.

14 STARTING UP

- Check electrical connections and gas connections.
- Check mechanical zero of the indication; if necessary adjust zero position by turning the slotted screw in the pane of the indication instrument.
- Turn measuring range selection switch to 30 %.
- Switch on mains voltage.
- The indication instrument shows 21 % O₂ with ambient air in the measuring cell and the LED for heater control lights up permanently.
- After approximately 30 min. the LED in the indication instrument starts flashing. After 12 hours the transmitter has reached a temperature balance and the analyzer is ready for calibration.

15 CALIBRATION

Before executing the calibration, the safety instructions relating to the installment and the process must be heeded!

The precision of the measurement depends on the precision of the analyzers calibration.

The linearity of the measuring ranges allows a two-point calibration, the zero calibration and the span calibration.

A weekly calibration of the analyzer guarantees the required precision of the measurements. Due to the direct proportional dependance of the oxygen indication to the barometric respectively process pressure, the calibration interval may be decreased to one day in case there are great variations of pressure.



NOTE!

Always carry out a calibration under measuring conditions, i.e. keeping the flow rate, the room temperature and the barometric pressure at a constant level. Avoid vibrations!

15.1 ZERO CALIBRATION

The zero calibration of the analyzer happens with a O₂-free gas, e.g. Nitrogen (N₂) 5.0. The following steps have to be carried out:

- Connect a flexible PVC- or FEP-hose with the pressure reducer of the N₂-zero-gas bottle.



DANGER!

The pressure reducer should have a maximum outlet measuring range of 0-1.5 bar abs. and should always be adjusted to a low outlet pressure of max. 0.1 bar. This protects the measuring cell against destruction due to high pressure!

- Open the bottle valve and then the closed pressure reducer outlet valve;

- Purge the pressure reducer and the complete hose line for approximately 5 sec.;
- Check the adjusted control pressure and reduce if necessary to ≤ 0.1 bar, then shut off the pressure reducer valve again.
- Connect the free hose end of the zero gas bottle connection to the gas inlet of the analyzer or if existing to the external calibration valve;
- Open pressure reducer outlet valve slowly to prevent pressure peaks.
- Adjust the flow rate to 50 NI/h at the flow meter.

**NOTE!**

Always calibrate at the flow rate that is adjusted for the measurement too.

- Wait approx. 30 seconds until stabilisation of the display;
- Set the measuring range selection switch to 3 % O₂;
- If necessary, adjust the zero point with a screw driver to 0 % via the zero point potentiometer 3 (figure 2) in the front panel of the analyzer;
- Check the analogue output signals at D-sub-connector X4 (see figure 2 und 7) at 0.0 % O₂:

Output signal	Measurement
0-1 V	0 V
0-20 mA	0 mA
4-20 mA	4 mA

**NOTE!**

If a gas mixture is analyzed, the single gas components have to be checked concerning potential cross sensitivity and regarded for zero calibration. (see chapter 17).

- Shut off pressure outlet valve and bottle valve.
- Disconnect hose connection from the analyzer.
- Zero calibration is finished.

**NOTE!**

After zero calibration the span always has to be calibrated too.

15.2 SPAN CALIBRATION



In case the oxygen concentration of the sample gas is below 30 % O₂, the calibration can be performed with dry air. Should the concentrations be higher, ideally, the test gas should correspond to the span value!

Before calibrating the span value, always check the zero point.

The following calibration procedure has to be carried out:

- Adjust measuring range selection switch to the range in which the calibration will be carried out.
- Connect the flexible PVC or Viton tube with the bottle pressure reducer of the test gas bottle, if necessary with ambient air or instrument air.



The pressure reducer should have a maximum outlet measuring range of 0-1.5 bar abs. and should always be adjusted to a low outlet pressure of max. 0.1 bar. This protects the measuring cell against destruction due to high pressure!

- First open the bottle valve, then open the closed output valve of the pressure regulator;
- Flush the pressure regulator and the tubing for about 5 seconds;
- Check adjusted control pressure and reduce to ≤ 0.1 bar if necessary then shut the outlet valve of the pressure regulator again.
- Connect the free tube end of the test gas bottle connection with the gas inlet of the analyzer or, if available, the external calibration valve;
- Open slowly the output valve of the pressure reducer in order to avoid pressure peaks;
- Set the test gas volume flow to approx. 50 l/h by means of the needle valve of the flow meter.



Always calibrate at the gas flow used for the measurement too.

- Wait approximately 20 – 30 sec. until the indication has stabilised.
- If necessary adjust span accurately according to the check gas concentration with a screw driver at the span potentiometer **2** (figure 2) in the front panel. In case of air e.g. to 20.9 % O₂.
- Check the analog output signals:



- The signal to be measured can be calculated as follows:

$$\text{Measured value} = \frac{(\text{max. signal output} - \text{min. signal output}) \times \text{Concentration [\%]}}{\text{Measuring range span value [\%]}} + \text{min. Signal output}$$

A test gas concentration of 20.93% (air) would result in the following:

Output signal	Signal to be measured with span value	
	100 %	
0-10 V DC	2.09 V	
Output signal	Signal to be measured with span value	
	30 %	100 %
0-20 mA	13.95 mA	4.19 mA
4-20 mA	15.16 mA	7.35 mA



NOTE!

The mA-signal depends on the adjusted measuring range. Therefore, it is important to check the correctness of the measuring range chosen!

- Shut the output valve of the pressure regulator and the bottle valve and separate the tube connection to the analyzer.
-

The span calibration has been completed.

ATTENTION!

**After completion of calibration set measuring range selection switch to desired measuring range again.
The mA-output signal is dependent on the measuring range!**

16 MEASURING

For the first starting up at a new location, all steps in the chapters before have to be performed. By the requirements of precision the interval of the new calibration can be carried out daily or weekly. The sample gas quantity should be adjusted corresponding to the requirements between 10 NI/h and 60 NI/h air. After choice of the desired measuring range the analyzer is ready for operation.

CAUTION!

The sample gas must be free from all liquid or solid particles, i.e. the dew point of the gas has to be below the equipment temperature so that no condensate will occur inside the equipment. If necessary, lower the dew point by means of a cooler or dryer. For dust filtration use a filter of 2 micron porosity!

We will be pleased to inform you about an optimal gas conditioning



NOTE!

Basically measurements should be carried out only with flow quantity and room temperature held constant.

17 CROSS SENSITIVITIES

The following table shows the cross sensitivities of the most important gases at 20 °C and 50 °C. All values are based on a zero calibration with N₂ and a span calibration with 100 vol% O₂. The deviations are each valid for 100 vol% of the respective gas.

Gas	Molecular formula	20 °C	50 °C
Acetaldehyde	C ₂ H ₄ O	- 0.31	- 0.34
Acetone	C ₃ H ₆ O	- 0.63	- 0.69
Acetylene	C ₂ H ₂	- 0.26	- 0.28
Ammonia	NH ₃	- 0.17	- 0.19
Argon	Ar	- 0.23	- 0.25
Benzene	C ₆ H ₆	- 1.24	- 1.34
Bromine	Br ₂	- 1.78	- 1.97
Butadiene	C ₄ H ₆	- 0.85	- 0.93
n-Butane	C ₄ H ₁₀	- 1.10	- 1.22
Iso Butylen	C ₄ H ₇	- 0.94	- 1.06
Chlorine	Cl ₂	- 0.83	- 0.91
Diacetylene	(CHCl) ₂	- 1.09	- 1.20
Nitrous monoxide	N ₂ O	- 0.20	- 0.22
Ethane	C ₂ H ₄	- 0.43	- 0.47
Ethylbenzene	C ₈ H ₁₀	- 1.89	- 2.08
Ethylene	C ₂ H ₄	- 0.20	- 0.22
Ethylene glycol	(CH ₂ OH) ₂	- 0.78	- 0.88
Ethylene oxide	C ₂ H ₄ O ₂	- 0.54	- 0.60
Furan	C ₄ H ₄ O	- 0.90	- 0.99
Helium	He	+ 0.29	+ 0.32
n-Hexane	C ₆ H ₁₄	- 1.78	- 1.97
Hydrogen chloride	HCL	- 0.31	- 0.34
Hydrogen fluoride	HF	+ 0.12	+ 0.14
Hydrogen sulfide	H ₂ S	- 0.41	- 0.43
Carbon dioxide	CO ₂	- 0.27	- 0.29
Carbon monoxide	CO	- 0.06	- 0.07
KryptonKr	- 0.49	- 0.54	
Methane	CH ₄	- 0.16	- 0.17
Methanol	CH ₄ O	- 0.27	- 0.31
Methylen chloride	CH ₂ Cl ₂	- 1.00	- 1.10
Methyl propene	C ₄ H ₈	- 0.94	- 1.06
Monosilan	SiH ₄	- 0.24	- 0.27
Neon	Ne	+ 0.16	+ 0.17
n-Octane	C ₈ H ₁₈	- 2.45	- 2.70
Phenol	C ₆ H ₆ O	- 1.40	- 1.54
Propane	C ₃ H ₈	- 0.77	- 0.85
Propylene	C ₃ H ₆	- 0.57	- 0.62
Propylene chloride	C ₃ H ₇ Cl	- 1.42	- 1.44
Propylene oxide	C ₃ H ₆ O	- 0.90	- 1.00
Oxygen	O₂	+100.00	+100.00
Sulfur dioxide	SO ₂	- 0.18	- 0.20
Sulfur fluoride	SF ₆	- 0.98	- 1.05
Monosilane	SiH ₄	- 0.24	- 0.27
Nitrogen	N₂	0.00	0.00
Nitrogen dioxide	NO ₂	+ 5.00	+ 16.00
Nitrogen monoxide	NO	+ 42.70	+ 43.00
Styrene C ₈ H ₈	- 1.63	- 1.80	
Toluene	C ₇ H ₈	- 1.57	- 1.73
Vinyl chloride	C ₂ H ₃ Cl	- 0.68	- 0.74
Vinyl fluoride	CH ₃ F	- 0.49	- 0.54
Water (Steam)	H ₂ O	- 0.03	- 0.03
Hydrogen	H ₂	+ 0.23	+ 0.26
Xenon	Xe	- 0.95	- 1.02

The selectivity of the above mentioned measuring principle is based on the high susceptibility of oxygen to other gases (see table).

The following examples shall show how cross sensitivities can be considered for the zero calibration.

Example 1: Determination of the rest content of oxygen in a 100% carbon dioxide (CO₂) protective atmosphere at 20 °C

In the table of cross sensitivities, you can read the value for CO₂ at 20 °C of –0.27. This means that for calibration with nitrogen the zero point must be set to +0.27 % in order to compensate the deviation of the display.

In this example, the atmosphere contains exclusively CO₂ and O₂. For this reason, the influence of cross sensitivity can be eliminated without problem by using carbon dioxide (CO₂) instead of nitrogen for the zero calibration.

Example 2: Determination of the oxygen content of a gas mixture at 20 °C

1 vol% C₂H₆ (Ethane);
 5 vol% O₂;
 40 vol% CO₂;
 54 vol% N₂.

Zero point calibration with nitrogen (N₂).

The cross sensitivity values of above table are based on 100 vol% of the respective gases. Therefore, a conversion must be made to the effective volume concentration. In principle, the following is valid:

$$\text{Effective cross sensitivity} = \frac{\text{Table value} \times \text{Volume concentration}}{100} \quad [\text{vol}\%]$$

For the components of the gas mixture, the following values are found:

C₂H₆ : -0.0043 vol%;

CO₂ : -0.1080 vol%;

N₂ : 0.0000 vol%.

Σ = -0.1123 vol%

To determine the sum of cross sensitivity as exactly as possible, a correction factor has to be determined, because the sum of cross sensitivities relates not on 100 % but on 100 % minus the oxygen concentration (here 95 %).

The correction factor is calculated as follows:

$$\text{Correction factor} = \frac{100}{(100 - \text{O}_2\text{-concentration})}$$

It is incidental:

$$\frac{100}{(100 - 5)} = \underline{1.0526}$$

For the gas mixture the rectified sum cross sensitivity then is calculated in good approximation:

$$1.0526 \times -0.1123 \text{ vol\%} = \underline{-0.1182 \text{ vol\%}}$$

The rectified sum cross sensitivity with change of sign now can be used for the correction of the zero calibration. In this case zero had to be adjusted at +0.1182 vol%.

In case the cross sensitivities should be ignored in the above-mentioned example, this would result in a relative error of approximately 2 %.



NOTE!

After zero calibration the span has always to be calibrated too.

If the span is not calibrated with 100 vol% oxygen here eventually it is also a correction of the cross sensitivities necessary.

Example: span calibration with air

The correction factor is calculated as follows:

$$\text{Correction factor} = \frac{(100 - \text{O}_2\text{-concentration})}{100}$$

It is incidental:

$$\frac{100 - 20.93}{100} = 0.7907$$

For the gas mixture in example 2 the rectified sum cross sensitivity then is calculated in good approximation for 20.93 vol% oxygen:

$$0.7907 \times -0.1182 \text{ vol\%} = \underline{\underline{-0.0935 \text{ vol\%}}}$$

The rectified sum cross sensitivity with change of sign now can be used for the correction of the span calibration. In this case span has to be adjusted at:

$$20.93 \text{ vol\%} + 0.0935 \text{ vol\%} = \underline{\underline{21.02 \text{ vol\%}}}$$

18 CLOSING DOWN

In case of a short time closing down of the process control system, the analyzer should remain „ON“. No further precautions are required.

In case of a closing down of the analyzer for a longer period, it is recommended to flush the analyzer with dry and clean inert gas (eg. ambient air) in order to prevent a damage of the measuring cell by aggressive and corrosive liquid gases.

19 STORAGE AND TRANSPORT



NOTE!

The analyzer should be stored in a protected frost-proof area!

20 MAINTENANCE

Before carrying out any maintenance activities, the safety requirements specific to the instalment and the process must be heeded!



WARNING!

Dangerous voltage. Before carrying out any maintenance work, take the analyzer and all external switching circuits in connection with the analyzer off the mains.



NOTE!

Only original spare parts and those corresponding to M&C specifications must be used!

The physical measuring principle and the special design of the analyzer are minimizing the maintenance requirements.

The preceding components necessary for the sample gas conditioning are to be maintained according to the respective operating manuals.

The zero point and full scale calibration must be performed with the appropriate test gases according to the instructions.

Recommended interval of calibration for standard applications: 1 x per week.

20.1 REMOVAL OF THE MEASURING CELL

For dismantling the measuring cell, the following procedure is recommended:



WARNING!

Dangerous voltage. before carrying out any maintenance or repair activities, take the analyzer and all external switching circuits in connection with the analyzer off the mains!



- Remove cross-head-screws of the housing (lid: 2; bottom: 2; front: 4; back: 4);
- Remove lid;
- Remove black isolation cap carefully from transmitter unit;



WARNING!

Hot transmitter surface up to 55 °C. Touching may lead to burnings. Wear safety gloves!



WARNING!

Strong magnetic field. Before dismantling the transmitter unit, remove all sensible parts (e.g. wrist watch etc.)!

- Remove the green 2-, 3- and 4-pole plug-in connections X2, X3, X4 from the power supply board;
- Loosen the earth connection (green-yellow) of the transmitter unit;
- Remove 18-pole flat ribbon cable;
- Put the transmitter unit in a position as shown in figure 9 (18-pole plug must show to the right side).

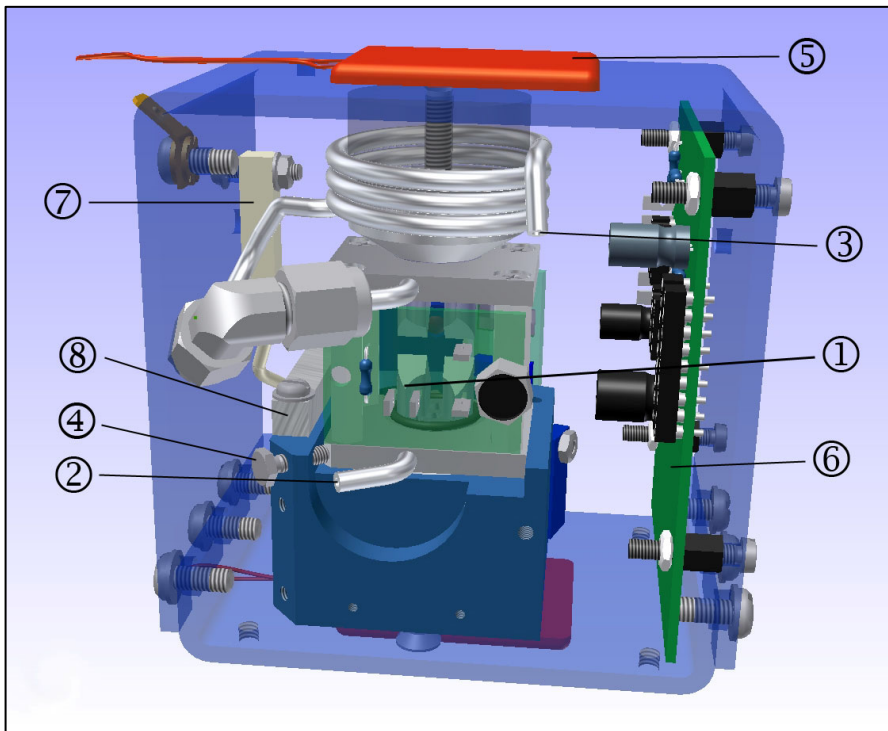

- | | |
|--------------------------------------|--------------------------------|
| ① Electrical connections meas. cell | ⑤ Heater element |
| ② Gas outlet measuring cell | ⑥ Transmitter board |
| ③ Gas inlet measuring cell | ⑦ Temperature cut out at 72 °C |
| ④ Fastening screw for measuring cell | ⑧ Temperature sensor |

Figure 9 **Transmitter unit**

- Unsolder the brown and yellow cable from the terminals **1** (see figure 9) on the back side of the measuring cell; do not overheat the terminals; mark the cables accordingly;
- Disconnect the tubing for the sample gas outlet **2** and elbow fitting at the sample gas inlet;
- Loosen the fastening screw of the measuring cell **4** with a screw driver;
- Push cell carefully out of the magnetic field with both thumbs. (Attention! The necessary power to this is not negligible.)
- Remove cell;
- Exchange only with measuring cells of the same type;

The mounting of the measuring cell is to be effected in reverse order; take care of the correct dumbbell position!



WARNING!

When using PTFE ferrules, they always have to be renewed.

In case there are minimally different positions of the dumbbells inside the measuring cells when mounting a new cell, it is absolutely necessary to adjust the zero point mechanically. The PMA30 housing can remain open for this purpose;

- Fix earthing cable (green-yellow) of the transmitter unit;
- Put on 18-pole flat ribbon cable to the transmitter;
- Put on the 2-, 3- and 4-pole green plug connections on the main board;
- Put black isolation cover over the transmitter unit.

20.2 MECHANICAL ZERO POINT ADJUSTMENT

The mechanical zero point adjustment has to be done as described in the following.

- Before switching on the analyzer, set range selector to 30 %. Control zero point of the analogue display and adjust it if necessary to 0 % via the adjustment screw below the digital display (Attention! dependent of position: observe position of use);
- Switch on the analyzer via external switch. Normally, the analogue display will indicate a value of 21 % oxygen because the cell is filled with ambient air;
- The warming up is indicated by the permanently beaming LED in the front plate of the analyzer; after approx. 30 minutes, the flashing display signalizes that the required operating temperature has been reached;
- Set the potentiometer for zero point and span value in the mid position; you can do this by turning the potentiometer with a screw driver fully to the left and then turn it five turns back to the right;
- Charge the analyzer with a zero gas volume flow of approx. 40 l/h;
- With a precise adjustment of the zero point, the analogue display should indicate 0.0 vol% oxygen;

If this does not happen, please execute the following steps:

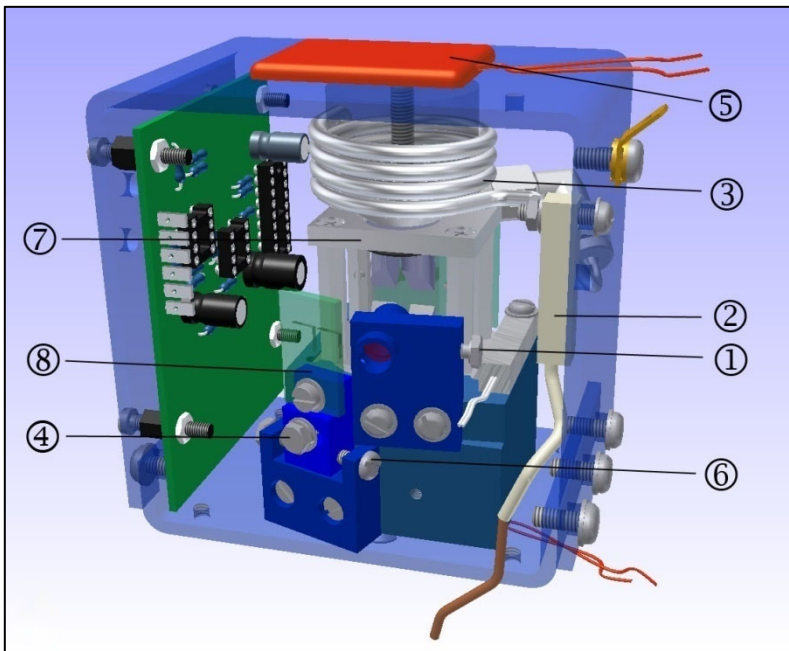

- | | |
|-------------------------------|------------------------------|
| 1 IR LED | 5 Heater element |
| 2 Temperature cut out (72 °C) | 6 Adjustment screw photocell |
| 3 Sample gas heating coil | 7 Measuring cell |
| 4 Fastening screw photocell | 8 Photocell |

Figure 10 Schematic view of the transmitter unit

- Open the housing of the analyzer;
- Remove carefully the isolating cap of the transmitter unit; now, all screws of the photocell fixing are visible (see figure 10);
- Set the range switch to 3 %;
- Loosen fixing screw **4** of the photocell carefully;



WARNING!

The screw must not be loosened too much, because the measuring value will change too much when later fixing the screw.

- Turn the adjustment screw **6** (see figure 10) of the photocell as long clockwise or anticlockwise as on the display appears a value of nearly 0.0 vol% oxygen;
- After the mechanical zero point adjustment, the fixing screw of the photocell fixing **4** must be screwed down again; take care that meanwhile the measuring value will not change!;
- Now, the zero point adjustment has been done;
- Place carefully the isolating cap on the analyzer and close it according to.
- A calibration of the device is now necessary and should be done when the transmitter has reached a temperature equilibrium.

21 TROUBLE SHOOTING

Error	Possible reason	Check/Repair
No indication	No supply voltage	Check supply voltage according to type plate. Check whether mains cable is plugged in accurate. Check fine fuse in the low heat device socket. Check fine fuses F1, F2 (TR5) on main board (next to transformer)
No sample gas flow	Sample line or filter is blocked Contamination of the internal diaphragm pump	Check sample system.
B11 lights up	Fault High (Measuring range exceeded > 3.125 %) (> 20.5 mA)	Can be switched off via JP14 Adapt measuring range Span potentiometer defective?
B5 lights up	Fault Low (values below measuring range more than 4.375 %) (< 3.2 mA)	Can be switched off via JP12 Zero calibration necessary? Zero potentiometer defective?
B6 lights up	Error internal measuring range selection	Measuring range selection switch defective (no contact)
B2 lights up	Coupling signal error	Can be switched off via JP6 The measuring cell is not coupling, contaminated or the LED is too dark or coupling sensor is defective. Attention: consideration of functional safety is based on this coupling error! JP6 has to be adjusted to 2-3! (enable coupling error)
B3 lights up	LED short-circuit error	Transmitter-projections-LED defektive
B4 lights up	LED-circuit open error	Transmitter-Projektions-LED defektive or circuit interrupted
B9 lights up	-15V Power error	Transformer error or external undervoltage
B10 lights up	+15V Power error	Transformer error or external undervoltage
B13 lights up	Low temperature error	Can be switched off via JP8 Heating (P6) resp. fault message threshold (P14) adjusted correctly? Thermal fuse has triggered? Temperature sensor defective? Reference voltage defective or misadjusted (P13)
B8 lights up	Excess temperature error	Heating (P6) resp. fault message threshold (P14) adjusted correctly? Thermal fuse has triggered? Temperature sensor defective? Reference voltage defective or misadjusted (P13)
B7 lights up	Min. flow error	No flow, fault message threshold misadjusted (P20), flow sensor defective.
B12 lights up	Max. flow error	Can be switched off via JP3 Flow too high, fault message threshold misadjusted (P7, P8), flow sensor defective.

22 PROPER DISPOSAL OF THE DEVICE

At the end of the life cycle of our products, it is important to take care of the appropriate disposal of obsolete electrical and non-electrical devices. To help protect our environment, please follow the rules and regulations of your country regarding recycling and waste management.

23 SPARE PARTS LIST

Wear, tear and replacement part requirements depend on specific operating conditions. The recommended quantities are based on experience and they are not binding.

Oxygen analyzer PMA 30					
(C) Consumable parts					
(R) Recommended spare parts					
(S) Spare parts					
					Recommended quantity being in operation [years]
Part No.	Indication	C/R/S	1	2	3
90A1000	Digital panel meter for PMA30 LCD 3 ½ digit 18 mm.	T	-	-	1
90A0084	Extra charge for 4 ½ digit indication				
90A0080	Digital analog panel meter type PMA30	T	-	-	1
90A0084	Extra charge for 4 ½ digit indication				
90A0010	Measuring cell PMA30	T	-	-	1
90A0020	Zero/span potentiometer 5 kOhm	T	-	-	1
90A0015	Flowmeter glass 7-70 NI/h	T	-	-	1
90A3010	Solid state relay A3P-202N	T	-	-	1
90A3015	Temperature cut out 72 °C	T	-	-	1
90A3020	Temperature sensor	T	-	-	1
90A3095	D-connector plug 25 poles for PMA30	T	-	-	1
05V3215	Bulkhead union DN4/6, material: PVDF	E	2	2	2
05V6600	Ferrule DN4/6, material : PVDF	E	4	4	4
05V6605	Spare parts union nut DN4/6, material : PVDF	E	4	4	4

24 APPENDIX

- Safety manual according to SIL
- Circuit diagram main board PMA 30
- Assembly diagram main board PMA 30
- Jumper-Settings, test points, plugs for main-, front- and extension board
- Circuit diagram front board PMA 30
- Assembly diagram front board PMA 30
- Assembly diagram bus board PMA 30
- Circuit diagram extension board PMA 30
- Assembly diagram extension board PMA 30
- Connections for wall mounting housing
- PMA 30 in wall mounting housing
- SIL-declaration of conformity



Further product documentation can be seen and downloaded from our home page:
www.mc-techgroup.com

Safety handbook according to SIL

The indicated product corresponds to the following European and/or international standards about the functional security:

DIN EN 61508 parts 1 – 7 (2011) [corresponds to IEC 61508 : 2010]

Contemplated devices

It was contemplated the PMA 30 with part no. **03A2001 / 03A2001a** (PMA30A/D),
03A2005 / 03A2005a (PMA30D),
 the following options:

Options	
03A9165	Extra charge for PMA 30 as solvent resistant execution with measuring cell type PMC-1LB. Material: O-rings out of Kalrez®.
02A9005	Extra charge for PMA 20/30 in chlorine resistant execution with a special measuring cell type PMC-1CL2. All gas bearing tubes PTFE/PVDF equipped with purge gas connectors.
03A9150	Wall mounting housing out of aluminium type 30-19 with 19"-insertion system (3U/42TE), incl. clamp box, clamp boards and filter, with window. protection class: IP65.
01A9165	Extra charge for changed measuring range to 2.5/5/10/25/100 vol% O ₂ , for recorder outlet and digitalmeter (only for PMA30/D).
01A9165	Additional price for PMA measuring range change in 2.5/5/10/25/100 vol% for recorder output. (for PMA30/D only)
90A0006	Measuring cell PMC-1G with glass solder
90A0007	Measuring cell PMC-1G/T glass solder, Tantalum
90A0014	Measuring cell PMC-1, special cell without 104

Excluded are the options:

03A9535	Extra charge for electrical zero suppressing with process pressure compensation type SD/PD for PMA30, pressure range ± 0.6 bar, media wetted parts : stainless steel, PVDF, FKM. Not with SIL-certification!
03A9530	Extra charge for process pressure compensation type PD for PMA30, pressure range ± 0.6 bar, media wetted parts : stainless steel, PVDF, FKM. Not with SIL-certification!

As well as option 0-20 mA output.

Device description and safety function

The safety function of the device is the measurement of the oxygen concentration in the measuring cell which is provided as linear current signal 4-20 mA. The status relay as transmission of a summary fault indication is element of the safety function. Current signals < 3.2 mA and > 20.5 mA as well as an open status contact at X4 have to be evaluated as failure from a downstream device.

The SIL-qualification is valid for all adjustable measuring ranges. It applies for alarm of rising oxygen concentration (dangerous fault: oxygen signal is too low) as well as for alarm of decreasing oxygen concentration (dangerous fault: oxygen signal is too high).

For one channel and two channel operation of the oxygen analyzer PMA 30 the following parameters have been determined.

	Single channel 1oo1	Redundant 1oo2	Single channel 1oo1	Redundant 1oo2
Safety function	Measurement of the oxygen concentration		Measurement of the oxygen concentration	
Dangerous error	Oxygen signal <u>too low</u>		Oxygen signal <u>too high</u>	
Measuring range	Depending on the measuring task		Depending on the measuring task	
Device type	B (but without μ P and software)		B (but without μ P and software)	
Proof test interval	1 year		1 year	
MTTR	24 hr		24 hr	
SFF	91.71 %		96.74 %	
HFT	0	1	0	1
SIL-ability	2	3	2	3
β factor	—	5 %	—	5 %
PFD	3.21×10^{-4}	1.62×10^{-5}	3.21×10^{-4}	1.62×10^{-5}
λ_{du}	7.07×10^{-8} (pro h)		2.78×10^{-8} (pro h)	
λ_{dd}	4.16×10^{-7} (pro h)		4.16×10^{-7} (pro h)	
λ_{su}	3.66×10^{-7} (pro h)		4.09×10^{-7} (pro h)	
λ_{sd}	3.42×10^{-10} (pro h)		3.42×10^{-10} (pro h)	

Operating conditions

Ambient conditions:

Temperature: -10 °C bis $+45$ °C

Pressure: 0.9- 1.1 bar abs.

Vibrations have to be avoided.

The sample gas has to be dry (dew point 5 °C) and dust free and the sample gas inlet temperature is not allowed to exceed 50 °C. Generally a fine filter with min. 2 µm has to be installed upstream.

Sample gas has to discharge freely into atmosphere at the sample gas outlet because a pressure rise at the outlet and therefore in the measuring cell will result in false readings.

Especially the accuracy of the adjusted measuring range has to be observed, because the current outlet 4-20mA is dependent on the measuring range. If the measuring range is chosen externally it is mandatory necessary to interpret the external measuring indication (see figure 8). The current limitation has to be ≥ 21 mA. Current signals < 3.2 mA and > 20.5 mA as well as an open status contact at X4 have to be evaluated as failure from a downstream device.

The analyzer has to be maintained and calibrated regularly expertly according to the manufacturer's data.

The maintenance intervals for monitoring of inertization processes have to be specified according to leaflet BGI 518 of the Main Association of Trade Associations (= leaflet T 023 of the trade association chemistry) edition 07/2009. For other applications the leaflet BGI 836 of the Main Association of Trade Associations (= leaflet T 021 of the trade association chemistry) edition 07/2009 has to be applied.

Yearly proof test

Minimum once a year a proof test for the whole safety chain has to be performed. Thus also the yearly system check according to the Industrial Safety Regulation is covered.

For the analyzer the proof test comprises the regular calibration / adjustment (see chapter 15) as well as triggering and test of the switch function of the status relay (fail safe relay).

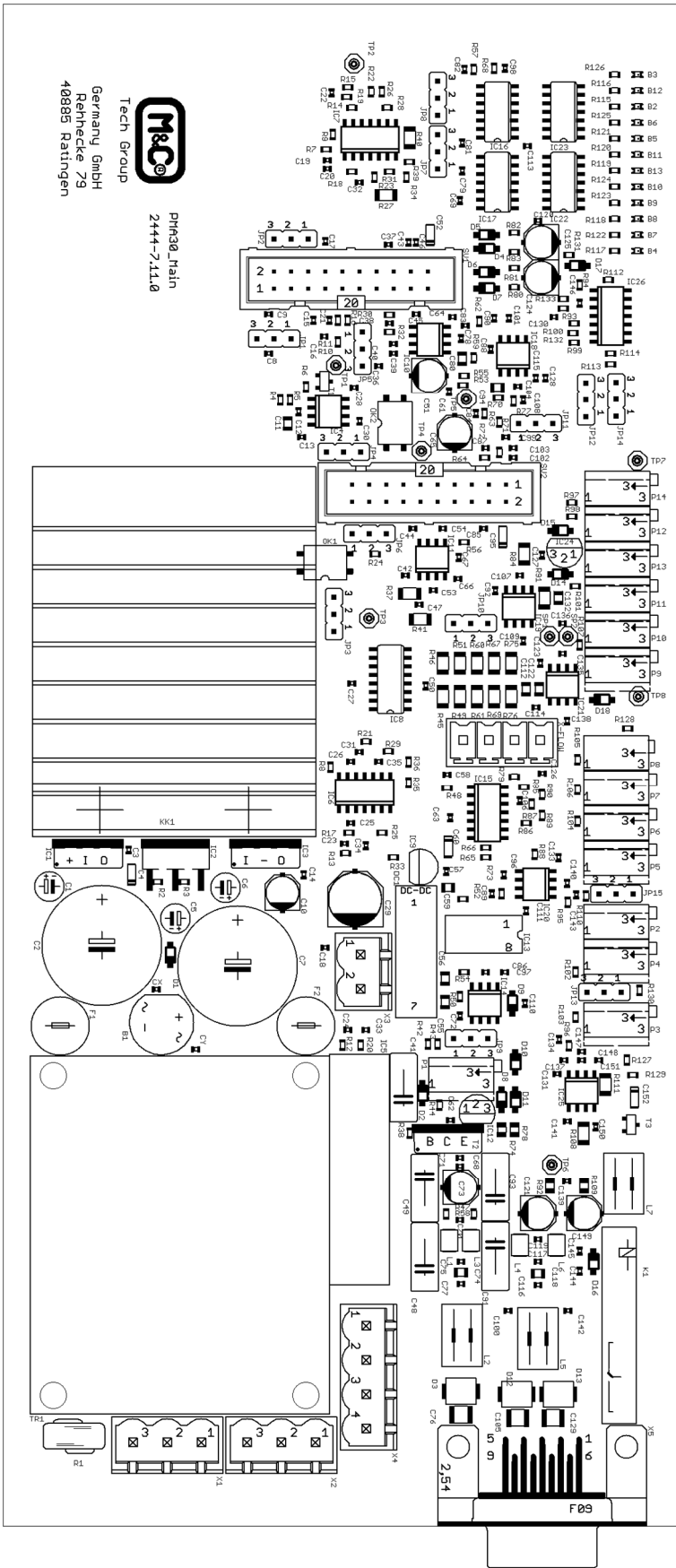

M&C
Tech Group
Germany GmbH
Rehbecke 79
40889 Ratingen

PMA30_Main
2444-7.11.0

- LED alarm short-circuit
- Flow alarm max.
- Couple signal
- Measuring range selection switch
- Measuring range lower deviation
- Measuring range exceedance
- Low temperature alarm
- +15 V power alarm
- 15 V power alarm
- Excess temperature alarm
- Flow alarm min.
- LED alarm open

- Offset O2 2. Op.-level
- Temperature alarm
- Range overflow alarm set point
- 5V reference O2-signal 0-10 V range
- Offset 1 range switch
- Span analog indication
- Offset 2 range switch
- Flow sensor min. alarm
- Flow sensor max. alarm rel. to min.
- Temperature set point
- Zero 4 mA
- 2+3: 0-20 mA / 1+2: 4-20 mA
- Zero 0 mA
- Span 4-20 mA
- 2+3: 0-20 mA / 1+2: 4-20 mA
- Span 0-20 mA
- Current limitation 20-22 mA

Figure 12 Assembly diagram PMA 30 main board

PMA30 Main board

Connections	Test points
X1 Power In	TP1 O ₂ in 2. op. level 0-5 V
X2 Temperature fuse	TP2 Temperaturalarm Sollwert
X3 Temperature sensor	TP3 GND
X4 Heating	TP4 Temperature actual value
X5 Current-, voltage-, status signal	TP5 O ₂ in 1. op. level
SV1 Measuring range choice, indication, compensation	TP6 GND
SV2 Transmitter	TP7 GND
X-Flow Flow sensor	TP8 O ₂ Measuring range amplifier 0-10 V

Jumper	Setting
JP1 Signal 10 V current outlet	2+3 non compensated / 1+2 pressure compensated
JP2 Measuring range amplifier inlet	2+3 non compensated / 1+2 pressure compensated
JP3 Flow alarm max.	2+3 Off / 1+2 On
JP4 Offset 1. Measuring range amplifier	2+3 O ₂ -signal / 1+2 0 V
JP5 O ₂ -signal / 5 V reference	2+3 O ₂ -signal / 1+2 5 V (100 % O ₂)
JP 6 Coupling sensor	2+3 On / 1+2 Off (e.g. nonexistent)
JP7 Excess temperature alarm	2+3 Off / 1+2 On
JP8 Low temperature alarm	2+3 Off / 1+2 On
JP 9 Load	2+3 800 Ω / 1+2 300 Ω
JP10 Offset 2. Measuring range amplifier	2+3 O ₂ -signal / 1+2 0 V
JP11 Offset O ₂ 1. op.-level	2+3 1.0p-level 0 V / 1+2 O ₂ -signal
JP12 Measuring range lower deviation	2+3 Off / 1+2 On
JP13 0/4-20 mA	2+3 0-20 mA / 1+2 4-20 mA
JP14 Measuring range exceedance	2+3 Off / 1+2 On
JP15 0/4-20 mA	2+3 0-20 mA / 1+2 4-20 mA

PMA30 Extension board

Connections	Test points
SV1: to Frontboard	TP1: GND
X1: Range selection IN/OUT	TP2: 5V reference
	TP3: Pressure signal 5 V = 1 bar
	TP4: Suppression signal 5 V = 100 %
	TP5: Compensated (suppr.) O ₂ signal
	TP6: Compensated O ₂ signal 10 V
	TP7: 10 V

Jumper	Setting
JP1: Zero suppression	1: Supression OFF
	2: Supression at 1 % range ON
	3: Supression at 3 % range ON
	4: Supression at 10 % range ON
	5: Supression at 30 % range ON
	6: Supression at 100 % range ON

PMA30 Front board

Connection	Test points
SV1: to extension board	None
SV2: to main board	
X1: to digital display	

Jumper	Setting
JP1: Signal to dig. display	2+3: compensated 1+2: non compensated

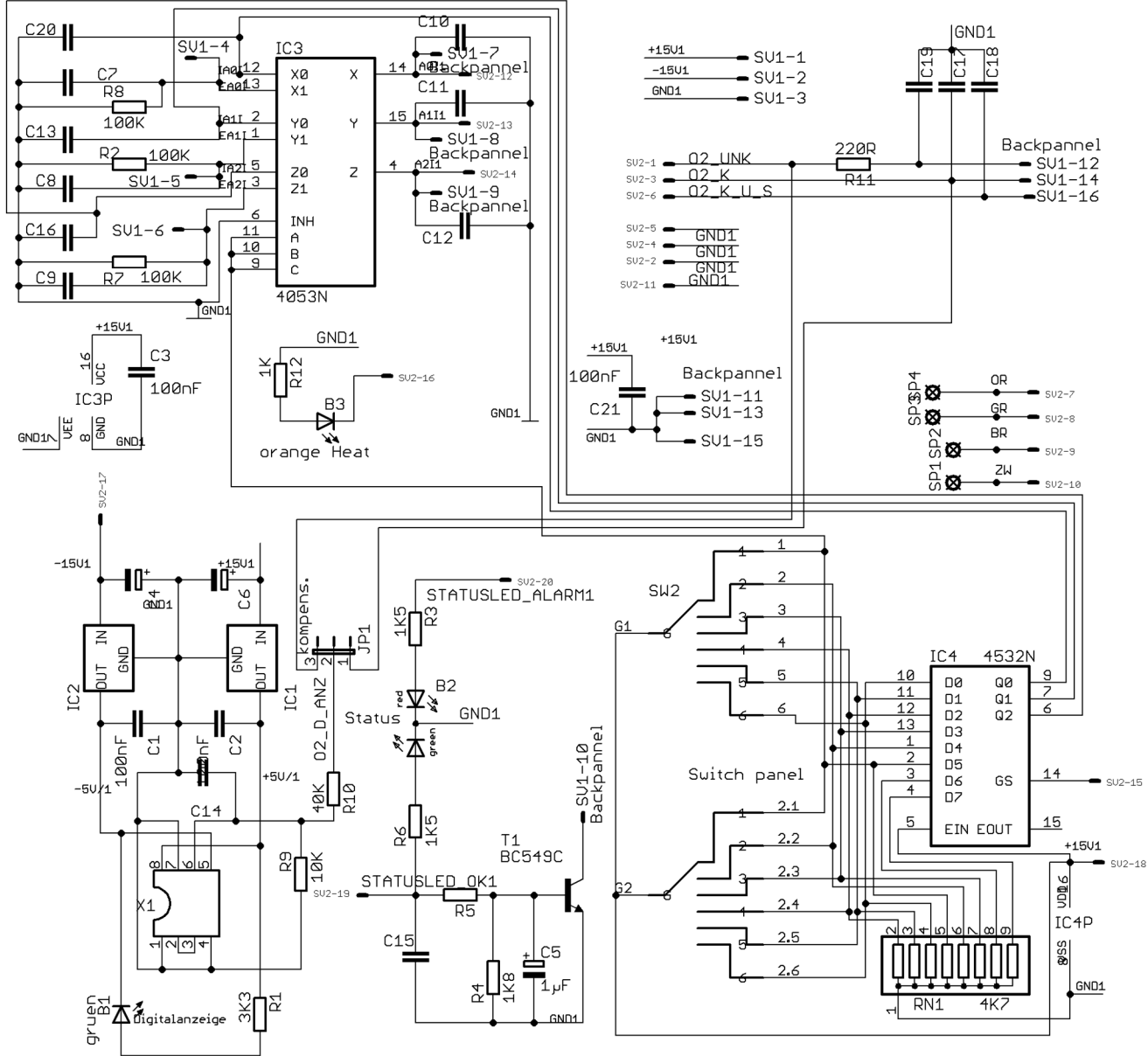

Figure 13 Circuit diagram PMA 30 front board

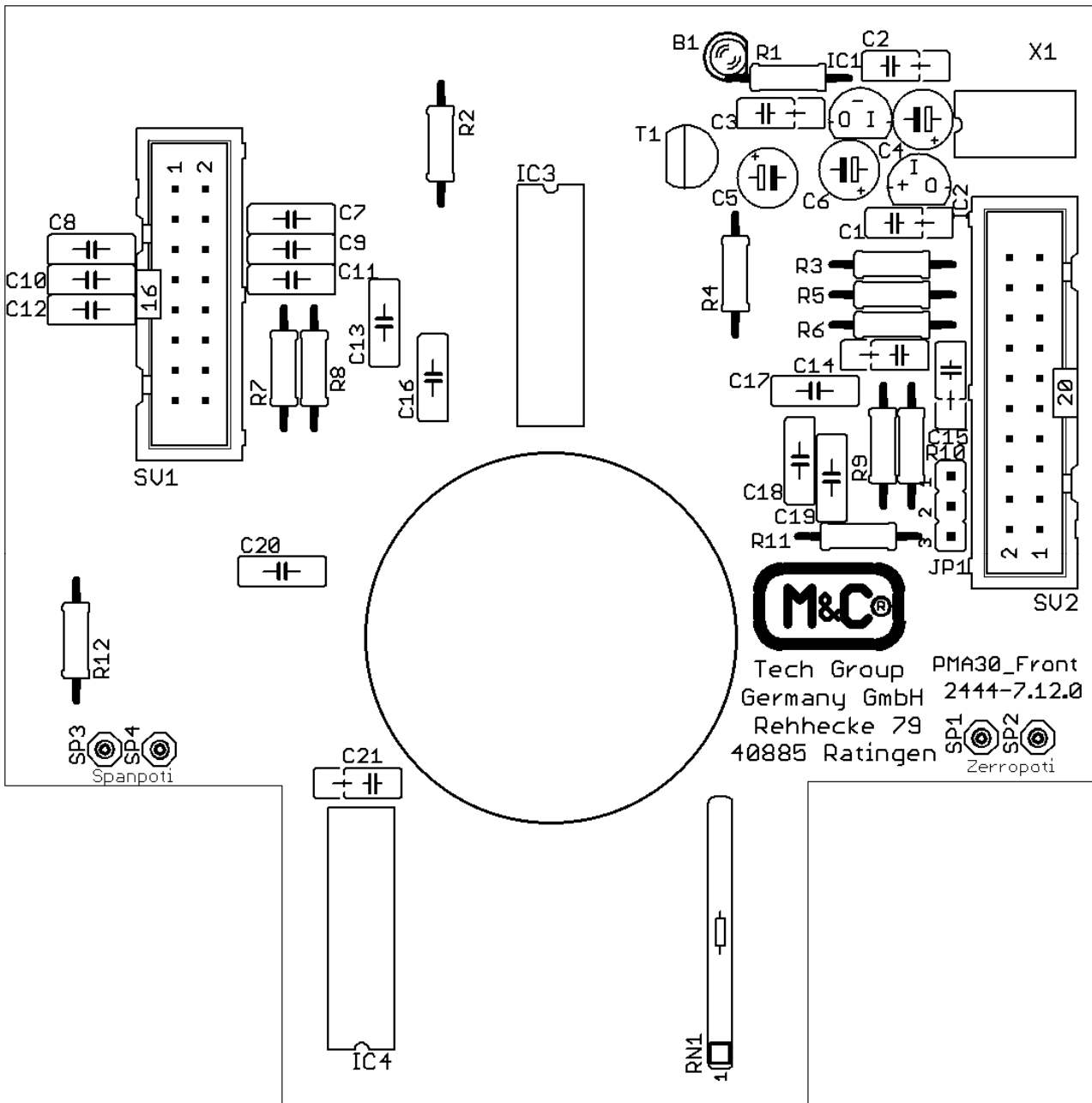

Figure 14 Assembly diagram front board PMA 30

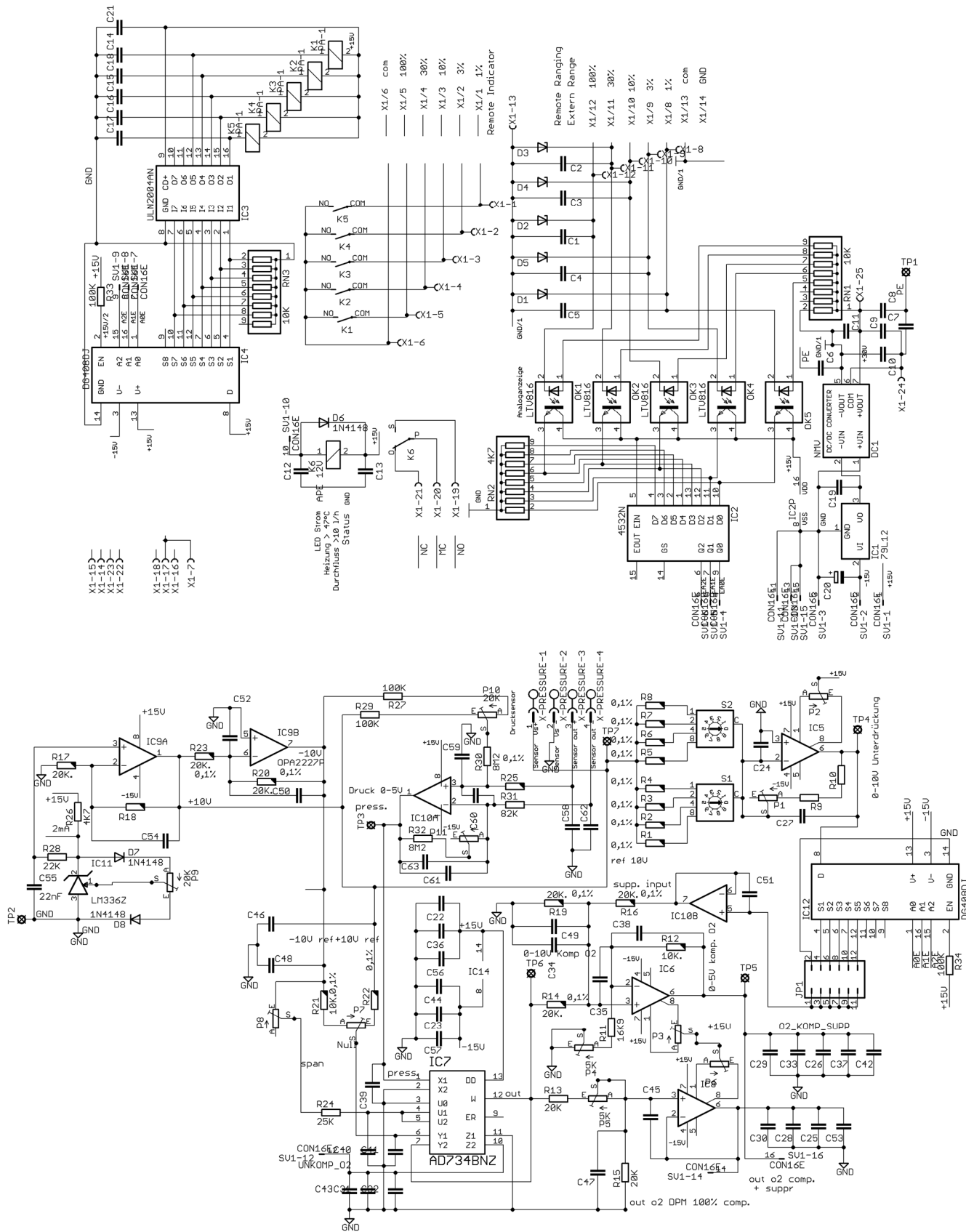

Figure 15 Circuit diagram extension board PMA 30

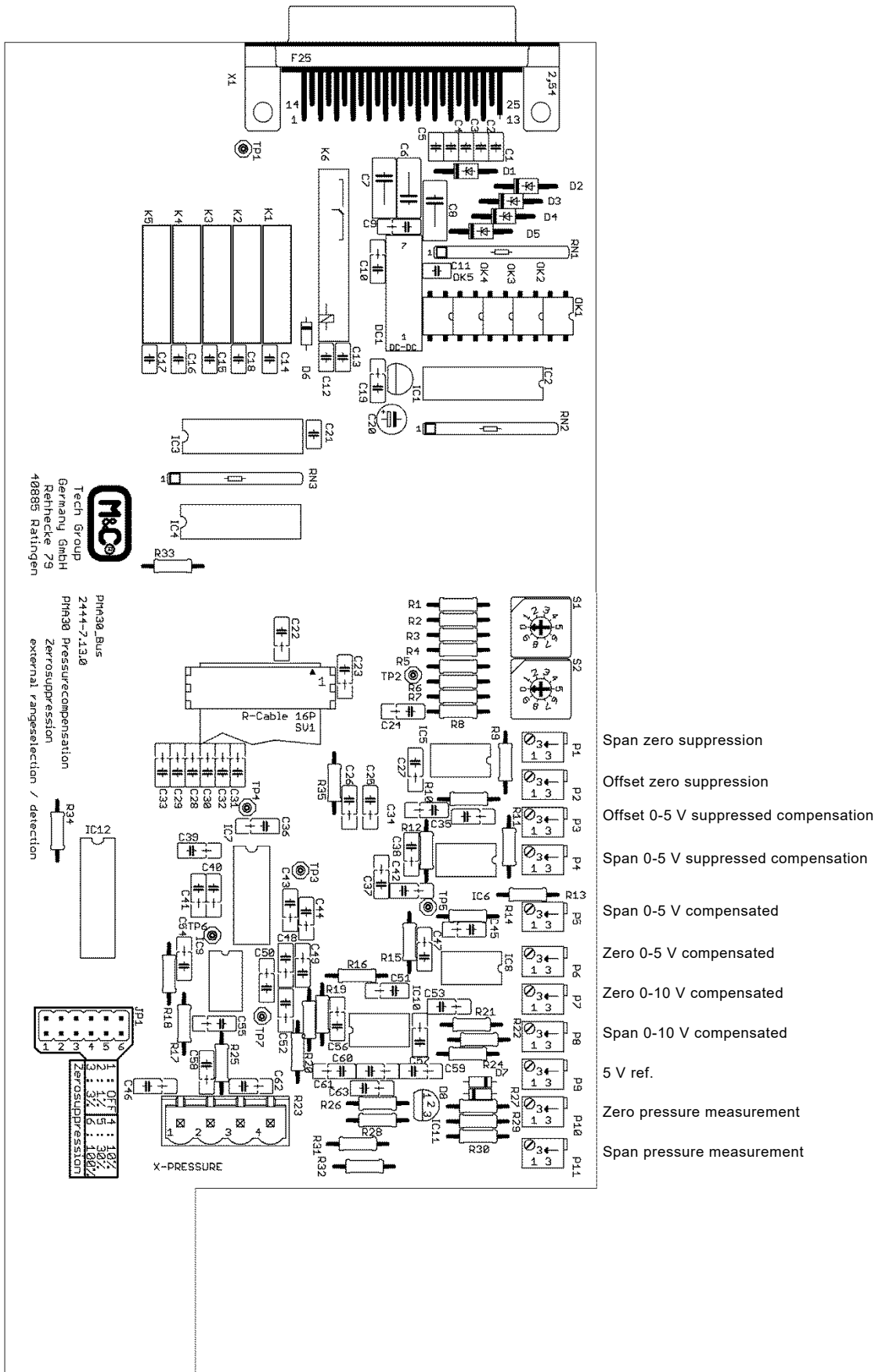

Figure 16 Assembly diagram extension board PMA 30

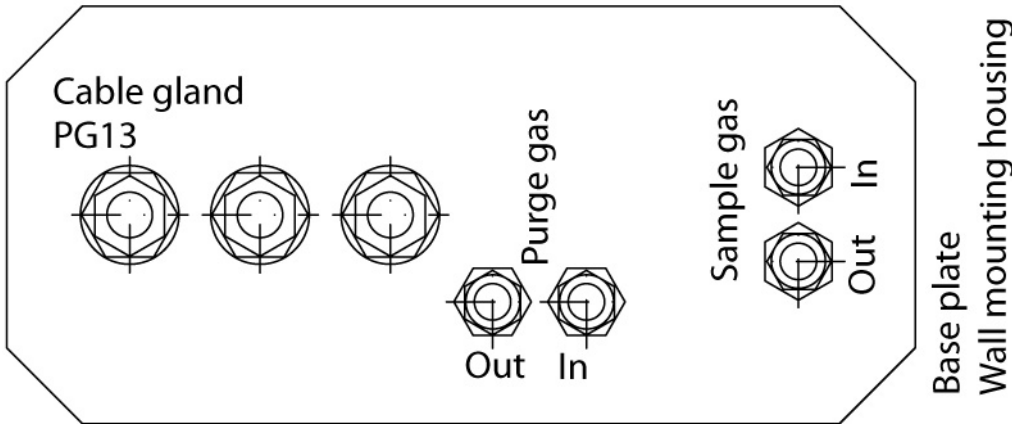
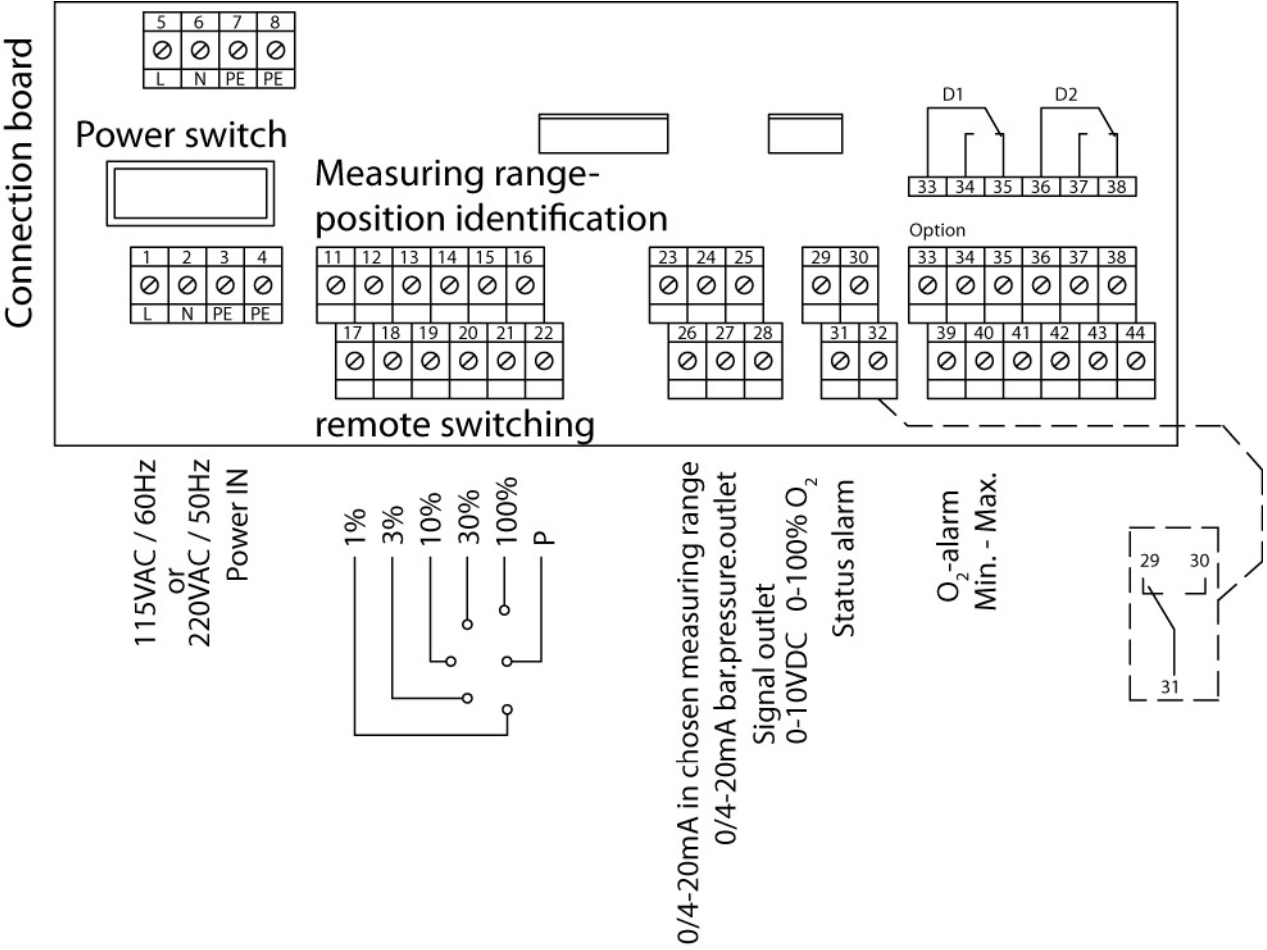

Figure 17 Connections wall mounting housing PMA 30

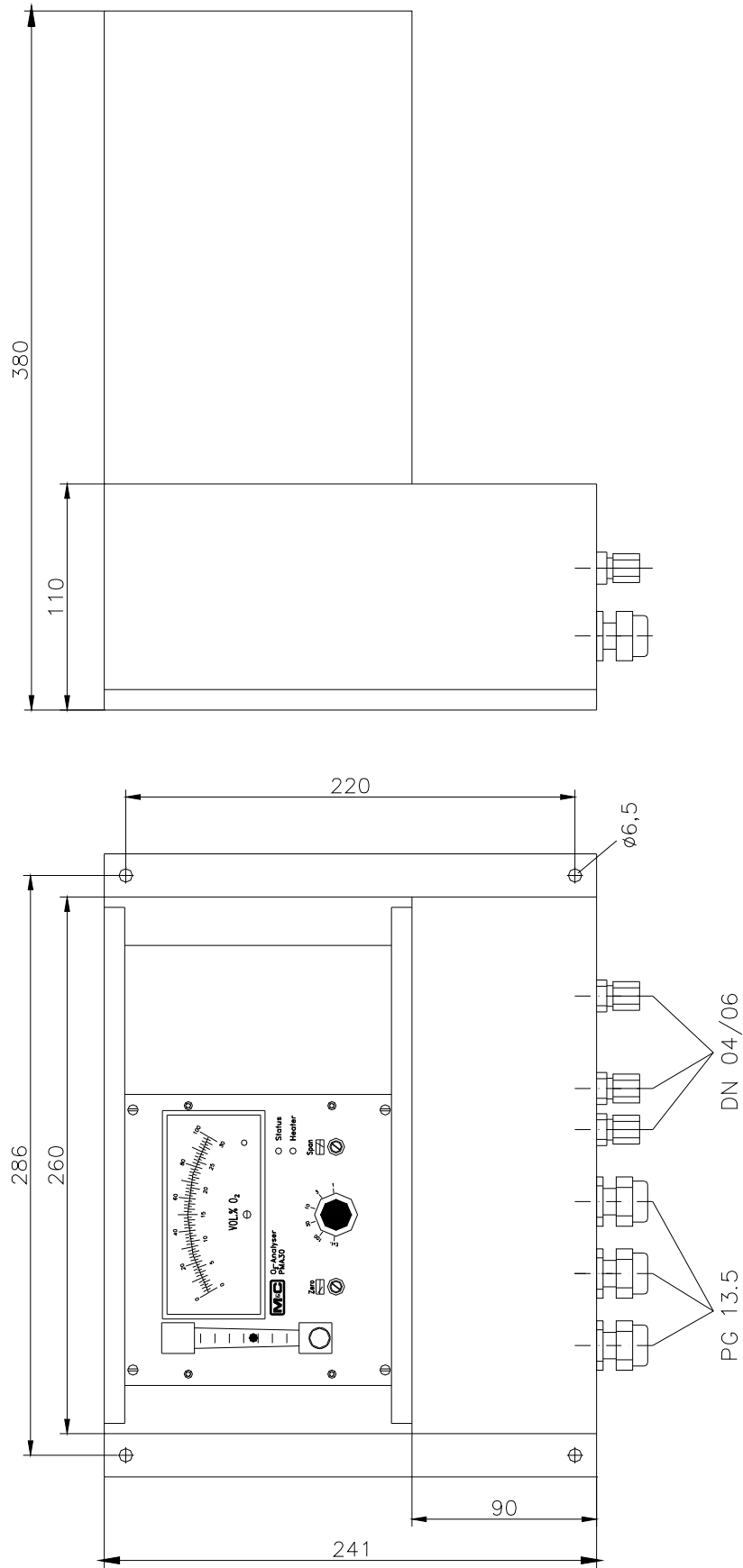

Figure 18

PMA 30 in wall mounting housing

SIL-Declaration of Conformity

Product name: **Oxygen Analyser PMA 30**

The described product complies with the following European / International Standards for Functional Safety

EN/IEC 61508:2010 parts 1 to 7

The following SIL-parameters were determined for single channel and dual channel (redundant) use of the oxygen analyser PMA 30. The Functional Safety Assessment was carried out by the company GWW GasWarn Dr. Wenker GmbH basing on the documentation and failure analysis of the company M&C. The correctness of the following data is confirmed by the company GWW GasWarn Dr. Wenker GmbH as independent consultant for SIL in the enclosed compliance statement.

Explanations for type "B" devices and for options of the analyser included into this study are given overleaf together with the conditions for use. For achieving the claimed SIL-capability these conditions for use have to be followed by the user.

	Single channel	Dual channel	Single channel	Dual channel
Safety Function	Measurement of oxygen concentration		Measurement of oxygen concentration	
Dangerous fault	Oxygen signal is <u>too low</u>		Oxygen signal is <u>too high</u>	
Measuring range	depending on application		depending on application	
Type of device	B (but without μ P and software)		B (but without μ P and software)	
Proof test interval	1 year		1 year	
MTTR	24 h		24 h	
SFF	91,71 %		96,74 %	
HFT	0	1	0	1
SIL-capability	2	3	2	3
β Faktor	—	5 %	—	5 %
PFD	$3,21 \times 10^{-4}$	$1,62 \times 10^{-5}$	$1,32 \times 10^{-4}$	$6,64 \times 10^{-6}$
λ_{du}	$7,07 \times 10^{-8}$ (per h)		$2,78 \times 10^{-8}$ (per h)	
λ_{dd}	$4,16 \times 10^{-7}$ (per h)		$4,16 \times 10^{-7}$ (per h)	
λ_{su}	$3,66 \times 10^{-7}$ (per h)		$4,09 \times 10^{-7}$ (per h)	
λ_{sd}	$3,42 \times 10^{-10}$ (per h)		$3,42 \times 10^{-10}$ (per h)	

Ratingen, November the 04th 2011

M&C TechGroup Germany GmbH

 Products Analystechnik GmbH

Reihenstraße 79, D-40895 Ratingen, Germany
ppa. Klaus Jörg

Fon +49 (0)2102 435-0
 Fax +49 (0)2102 435-111

info@muc-products.de
 www.muc-products.de

M&C_SIL-Declaration_of_Conformity_PMA_30.pdf

Page 1 of 2

 M&C TechGroup Germany GmbH
 Geschäftsführer Olaf Sommer

 Amtsgericht Düsseldorf HRB 53843
 USt-Ident-Nr. DE 814788475
 WEEE-Reg.-Nr. DE 99278920

 Bankverbindung
 Stadsparkasse Düsseldorf
 BLZ 300 501 10

 Konto 100 435 965 7
 BIC DUS5 DE DD
 IBAN DE 32300501101004359657

Type of device B

For "simple" devices (type A according to EN 61508) having well defined failure modes a SFF between 60 % and 90 % is sufficient to achieve a SIL-capability of 2. All devices comprising a microprocessor and software are belonging to the type B because their failure modes are complex. For those devices a SFF > 90 % is required.

The oxygen analyser PMA 30 does not contain software nor a microprocessor. Nevertheless the device was classified as type B device because several electronic components with integrated circuits are implemented which are having complex failure modes.

Device options included

The SIL-capability is valid for all measuring ranges adjustable. It applies for both, alarming at increasing oxygen concentration (dangerous fault: oxygen signal is too low) and for alarming at decreasing oxygen concentration (dangerous fault: oxygen signal is too high).

The solvent resistant (Option article 03A9165) and chlorine resistant (Option article 02A9005) execution of PMA30, are also included as a glass soldered Measurecell (article 90A0006), a glass soldered tantal coated Measurecell (article 90A0007) and epoxy-104 free Measurecell (article 90A0012).

Under assigned conditions of use, other future particular variations of Material at the Cell are not excluded.

Analysers with the option breathing and draining device (part no. 02A9005) or the option measuring cell in solvent resistant execution (03A9165) are included.

The output function considered is the 4 – 20 mA signal in relation with the status signal. Output signals of < 3,2 mA and > 20,5 mA as well as an open status contact have to be recognized as fault by a central unit or PLC monitoring the analyser.

Conditions for use

The values for the SIL-Capability of the analyser and the determined failure rates are valid only if the following conditions for use will be obeyed.

The safety instructions of the manufacturer's documentation have to be followed.

Environmental conditions: Temperature –10 °C to +45 °C ; Pressure: 0,9 to 1,1 bar absolute ; Vibrations have to be avoided.

The measuring gas shall be dry (dew point of 5 °C) and free of dust. The inlet temperature of the measuring gas shall not exceed 50 °C. the maximum allowed inlet pressure is 1,1 bar abs. for the standard analyser and 1,5 bar abs. for analysers equipped with the breathing and draining device.

Always use in front of the analyser a protective fine filter of 2 µm porosity.

At the outlet of the analyser the measuring gas has to discharge freely into atmosphere because an increase of pressure at the outlet will be also in the measuring cell and cause a false oxygen indication.

Because the 4 – 20 mA output signal is depending on the measuring range, the correctness of the chosen range has to be controlled. It is mandatory to monitor the remote range selection and indication (see fig. 8 in the instruction manual).

The current limitation has to be set to ≥ 21 mA.

Output signals of < 3,2 mA and > 20,5 mA as well as an open status contact at X4 have to be recognized as fault by a central unit or PLC monitoring the analyser.

The analyser has to be regularly calibrated and maintained by experienced personnel following the manufacturer's instructions.

Maintenance intervals have to be fixed according to national regulations e.g. for monitoring inertisation processes this is in Germany specified in "Merkblatt BGI 518" of the "Hauptverband der Berufsgenossenschaften" also cited as "Merkblatt T 023" of the "BG-Chemie". For other applications the German regulation is specified in "Merkblatt BGI 836" of the "Hauptverband der Berufsgenossenschaften" also cited as "Merkblatt T 021" of the "BG-Chemie".

Annual proof test

Minimum once per year a proof test has to be carried out for the whole safety function (safety chain). In Germany this is equivalent to the annual "system-control" of "Betriebssicherheitsverordnung".

For the analyser the proof test comprises a regular calibration / adjustment and checking the status relay (fault relay) by switching the contact.